

The Future of the High Energy Frontier

Latsis Symposium 2013
ETHZ, Uni Zürich, PSI, 5th June 2013



Fondation
Latsis
Internationale



Drawing by
Sergio Cittolin

Peter Jenni, Freiburg and CERN

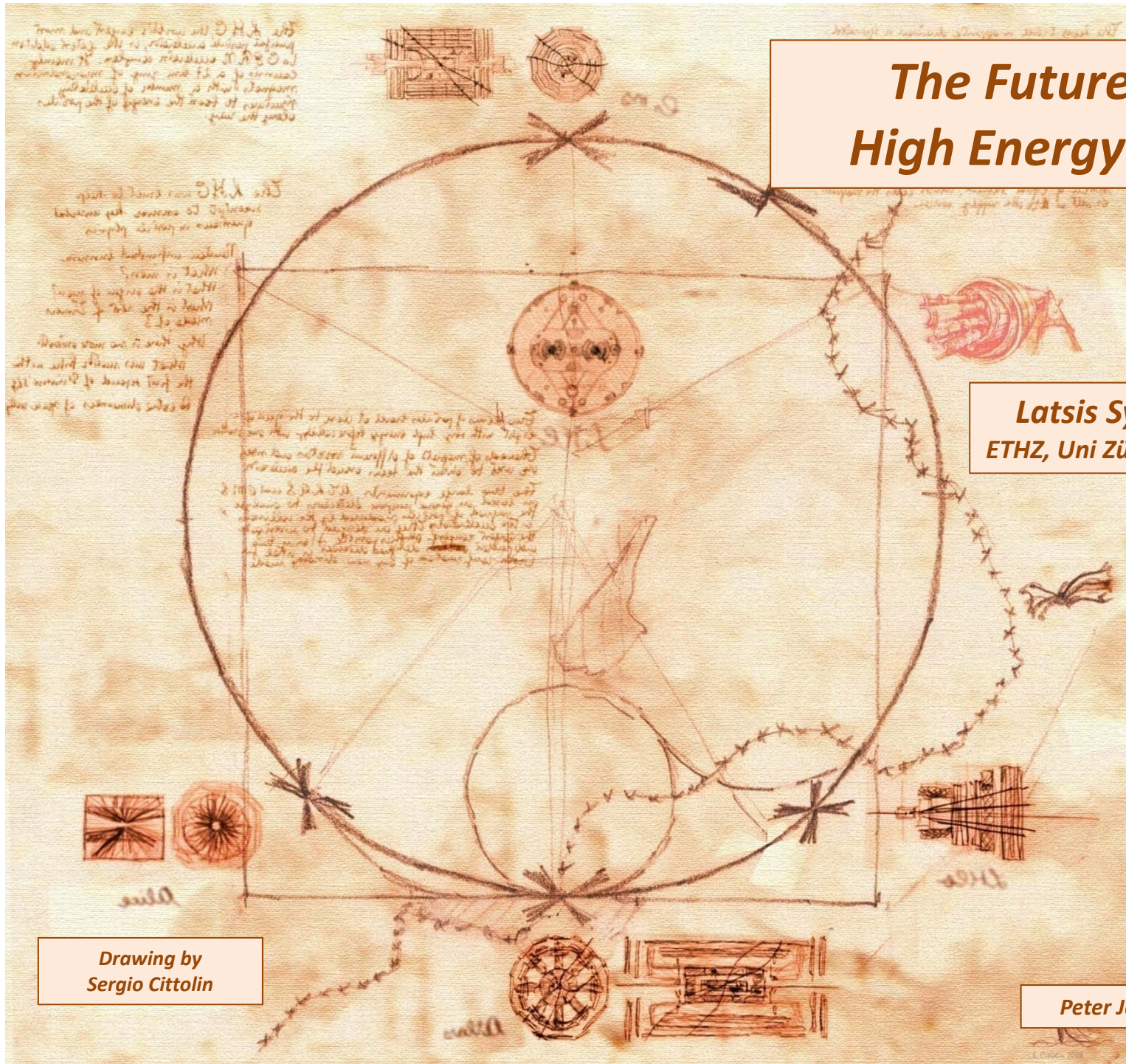

How could I tell?

All I can try to do is

- Reflect a bit on the past
- Recall some options
- **And in particular base myself on the recent Update of the European Strategy for Particle Physics**

(but most has already been said...)

In fact, this will be the main part:



Latsis, Zurich, 5 June 2013
P Jenni, Freiburg and CERN

High Energy Frontier



Update of the European Strategy (ES) for Particle Physics

Brief recall of the procedure and bodies

Concentrate on the outcome of the closed ES drafting meeting which took place at the Ettore Majorana Foundation and Centre for Scientific Culture (EMFCSC) in Erice from 21 to 25 January 2013, and which was then endorsed by Council in its March meeting, and finally approved on 30th May 2013 in Brussels in a special Council meeting

I will highlight a very selective set of topics only, the full set of statements will be available at the web site below, which also contains links to the further detailed public information



Erice (Sicily), 750 m



The time line

- Autumn 2011** **CERN Council initiated an update exercise to the European Strategy for Particle Physics which was approved by a special Council Session held in Lisbon on 14th July 2006**
- This included appointing formally a European Strategy Group (ESG) as well as a European Strategy Preparatory Group (ESPG)**
- February 2012** **ESPG started collecting written input from community**
- July 31st 2012** **Closing date for input to Open Symposium in Krakow**
- 10-12 Sep 2012** **Open Symposium in Krakow with more than 500 participants**
<http://espp2012.ifj.edu.pl/>
- October 15th 2012** **Closing date for community input to the Briefing Book**
- 21-25 Jan 2013** **2013 European Strategy Meeting in Erice produced a draft proposal to Council**
- March 22nd 2013** **Council finalized the strategy document (very minor clarifications)**
- May 30th 2013** **Final approval by Council in a special meeting in Brussels**

European Strategy Group (ESG)

Members

Member States Representatives

Austria	Prof. A. H. Hogang
Belgium	Prof. W. Van Doninck
Bulgaria	Prof. L. Litov
Czech Republic	Prof. J. Chyla
Denmark	Prof. J.J. Gaardhoje
Finland	Prof. P. Eerola
France	Prof. J. Martino
Germany	Prof. S. Bethke
Greece	Dr P. Rapidis
Hungary	Prof. P. Levai
Italy	Prof. F. Ferroni
Netherlands	Prof. S. De Jong
Norway	Prof. A. Read
Poland	Prof. J. Krolikowski
Portugal	Prof. G. Barreira
Slovakia	Dr L. Sandor
Spain	Prof. F. del Aguila
Sweden	Prof. B. Asman
Switzerland	Prof. K. Kirch
United-Kingdom	Prof. J. Butterworth

CERN - Director-General

Prof. R. Heuer

Major European National Labs

CIEMAT	Dr C. Lopez
DESY	Prof. J. Mnich
IRFU	Dr Ph.Chomaz
LAL	Dr A. Stocchi
NIKHEF	Prof. F. Linde
LNF	Dr U. Dosselli
LNGS	Prof. S. Ragazzi
PSI	Dr L. Rivkin
STFC-RAL	Dr J. Womersley

Strategy Secretariat Members

Prof. T. Nakada	Scientific Secretary (Chair)
Prof. F. Zwirner	SPC Chair
Dr M. Krammer	ECFA Chair
Dr Ph. Chomaz	Repres. EU Lab. Directors
Prof. E. Tsesmelis	Scientific Assistant

Invited - President of Council

Prof. A. Zalewska

Invitees

Candidate for Accession and Associate Member States

Israel	Prof. E. Rabinovici
Romania	Dr S. Dita
Serbia	H. E. Amb. U. Zvekcic

Observer States

India	Prof. T. Aziz
Japan	Prof. Sh. Asai
Russian Federation	Prof. A. Bondar
Turkey	Prof. Dr M. Zeyrek
United-States	Prof. M. Shochet

EU	Dr R. Lecbychova
ApPEC	Dr S. Katsanevas
Chairman FALC	Prof. Y. Okaka
Chairman ESFRI	Dr B. Vierkorn-Rudolph
Chairman NuPECC	Prof. A. Bracco
JINR, Dubna	Prof. V. Matveev

Former President of Council Prof. M. Spiro



Erice, ESG, January 2013

The European Strategy Preparatory Group (ESPG) Members

Strategy Secretariat Members

Prof. T. Nakada
Prof. F. Zwirner
Dr M. Krammer
Dr Ph. Chomaz
Prof. E. Tsesmelis

Scientific Secretary (Chair)
SPC Chair
ECFA Chair
Repres. EU Lab. Directors
Scientific Assistant

SPC

Prof. R. Aleksan (FR)
Prof. P. Braun-Munzinger (DE)
Prof. M. Diemoz (IT)
Prof. D. Wark (UK)

ECFA

Prof. K. Desch (DE)
Prof. K. Huitu (FI)
Prof. A. P. Żarnecki (PL)
Prof. C. De Clercq (BE)

CERN

Dr P. Jenni

ASIA/AMERICAS

Prof. Y. Kuno (Asia)
Prof. P. McBride (Americas)

Physics Briefing Book

Input for the Strategy Group to draft the update of the
European Strategy for Particle Physics

Compiled by

R. Aleksan, P. Braun-Munzinger, Ph. Chomaz, K. Desch, C. De Clercq,
M. Diemoz, K. Huitu, P. Jenni, M. Krammer, Y. Kuno,
P. McBride, T. Nakada, E. Tsesmelis, D. Wark, A. F. Żarnecki,
and F. Zwirner

European Strategy for Particle Physics Preparatory Group

and

P. Brun, E. Fernandez Martinez, R. Forty, E. Garutti, K. Kutak,
A. Lister, P. Slavich, and F. Zimmermann

Scientific Secretaries for the Open Symposium in Cracow, Poland

Briefing Book

The Briefing Book contains in 220 pages a 'digested summary' of the scientific and technical input to the European Strategy update (from 177 contributions and the Krakow Open Symposium)

Chapter headings

- 1- Introduction
- 2- Energy Frontier
- 3- Physics of Flavour and Symmetries
- 4- Neutrino Physics
- 5- Strong Interaction Physics
- 6- Astroparticle and Non-accelerator Physics
- 7- Particle Physics Theory
- 8- Accelerator Science and Technology
- 9- Instrumentation, Computing and Infrastructure

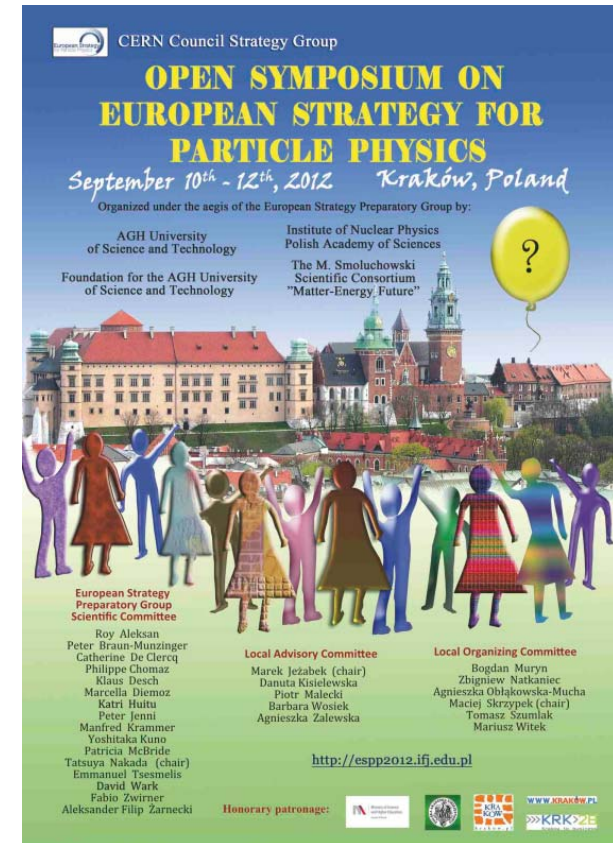

The present (public) draft version of the Briefing Book is available at the link given before, and a final version will be published in a few weeks

Latsis, Zurich, 5 June 2013
P Jenni, Freiburg and CERN

High Energy Frontier

ES Working Groups on organizational and other matters

Working Group 1 Mandate and organisational structure for the Council of the European Strategy and its implementation

Working Group 2 Organisational structure for European participation in global projects, including the role and definition of the National Laboratories and the CERN Laboratory in the European Strategy

Working Group 3 Relations with external bodies, in particular EU-related issues

Working Group 4 Knowledge and technology transfer, relations with industry

Working Group 5 Outreach, communication and education

The membership of these WGs consisted of members from the ESG plus some external experts

The famous three pillars of particle physics

When considering the scientific input to update of the European Strategy for Particle Physics, the bodies were very much aware of this complementarity

Another primordial consideration was the need to see the European Strategy within a global context of facilities worldwide, taking into account the global aspects of planning for future facilities

Latsis, Zurich, 5 June 2013
P Jenni, Freiburg and CERN

© P5: Particle Physics
Project Prioritization Panel

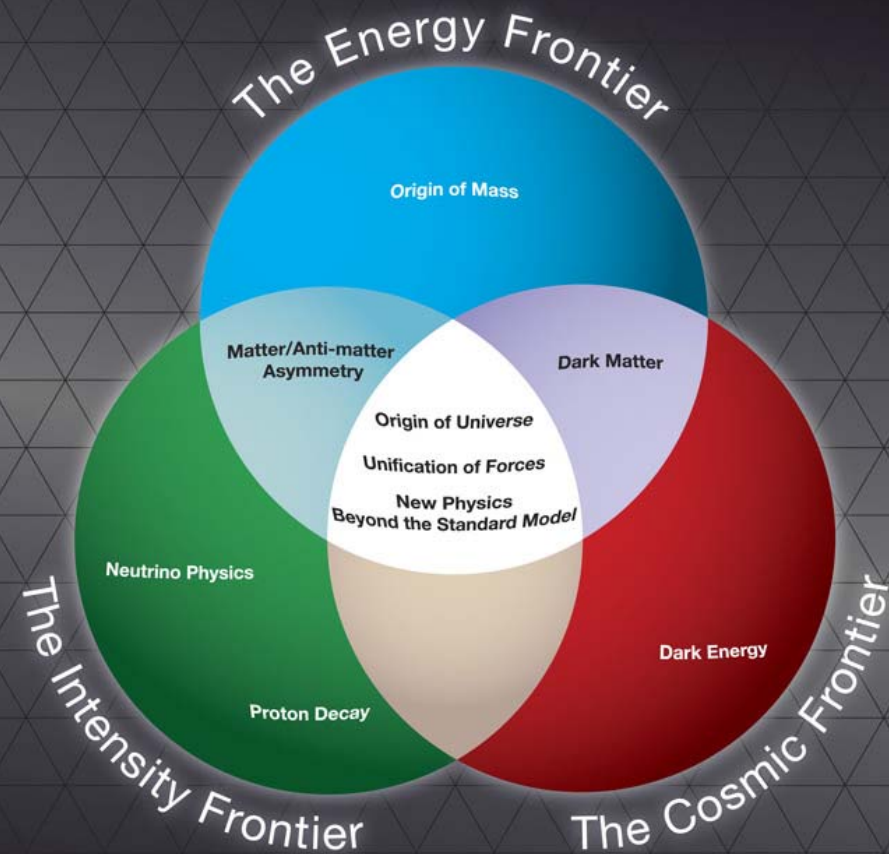

Note that non-accelerator particle physics such as p decay, $0\nu\beta\beta$ decay ... are under astro-particle physics coordinated by ApPEC in Europe

Placing the current high energy frontier collider, LHC, into the broader context

pp physics at the LHC corresponds to conditions around here

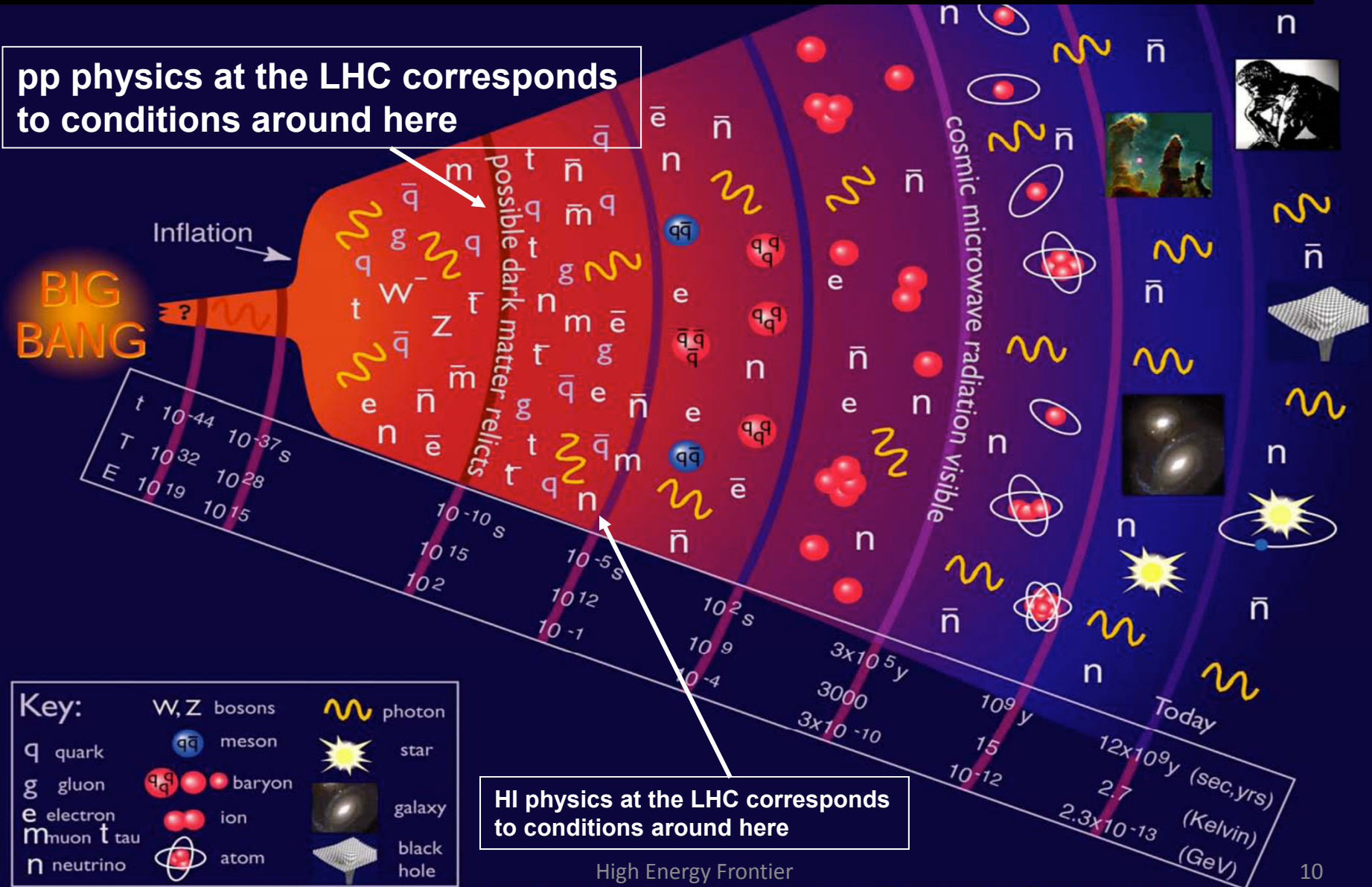

t 10^{-44} 10^{-37} s
 T 10^{32} 10^{28}
 E 10^{19} 10^{15}

10^{-10} s
 10^{15}
 10^2
 10^{-5} s
 10^{12}
 10^{-1}
 10^2 s
 10^9
 10^{-4}
 3×10^5 y
 3000
 3×10^{-10}
 10^9 y
 15
 10^{-12}
 Today
 12×10^9 y (sec,yrs)
 2.7 (Kelvin)
 2.3×10^{-13} (GeV)

Key:

W, Z bosons		photon	
quark		meson	
gluon		baryon	
electron		ion	
muon		atom	
tau		galaxy	
neutrino		black hole	

HI physics at the LHC corresponds to conditions around here

Before expanding further the high energy frontier, a short reminder on the high relevance of the intensity frontier for the future of particle physics

Beyond the Standard Model physics is probed by

- Neutrino physics
(~ already not fitting into the SM)**
- Precision measurements on rare and forbidden processes of quarks and charged leptons in the Standard Model**

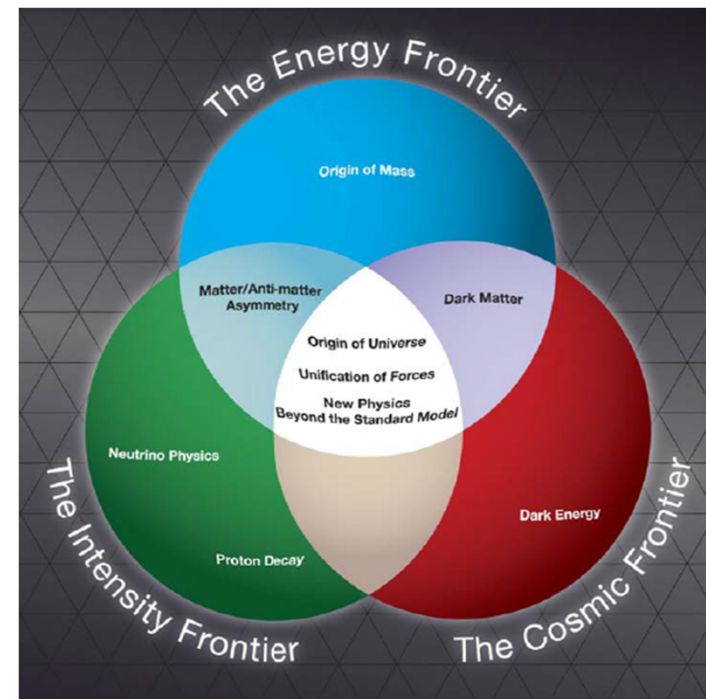

Neutrino physics

The crucial new experimental input is the measurement of the clearly non-zero value of the third mixing angle θ_{13} for neutrino flavour mixing by several experiments

Shown here is the Daya Bay reactor experiment which observed a deficit of anti- ν_e at its 1.6 km far detectors leading to

$$\sin^2 2\theta_{13} = 0.092 \pm 0.016(\text{stat}) \pm 0.005(\text{syst})$$

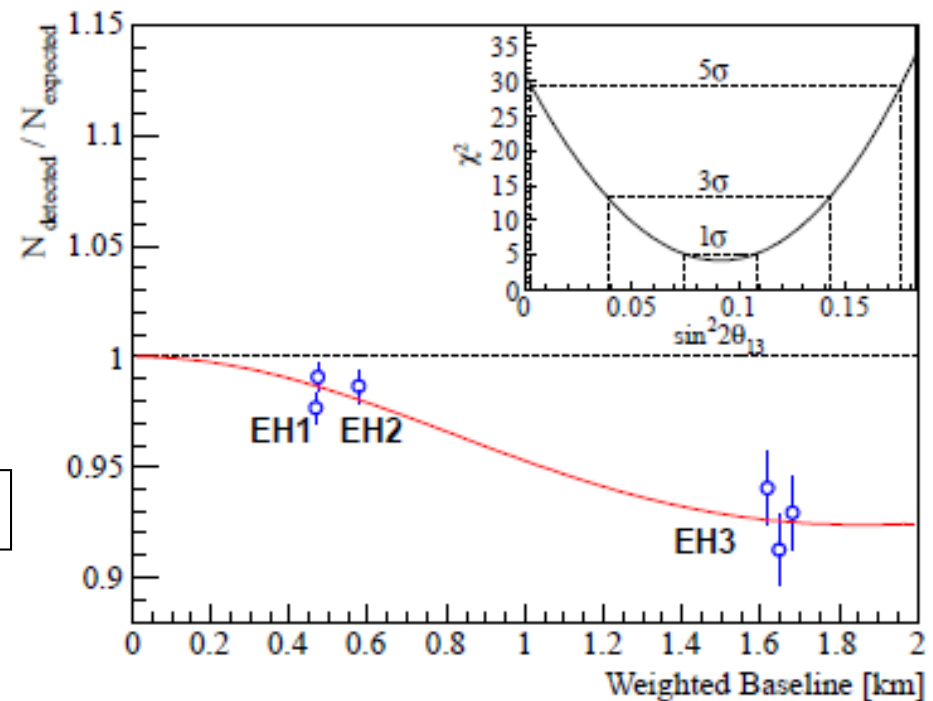

Possible CP violation requires all three mixing angles to be non-zero

Phys. Rev. Lett. 108 (2012) 171803

Mentioning here only large accelerator-based facilities, the goals of next generation long-baseline oscillation experiments:

- The mass hierarchy, that is , the sign of Δm^2_{31}
- The existence of leptonic CP violation in neutrino oscillations and the value of δ

There is in addition a world-wide rich activity of current and planned neutrino experiments: $0\nu\beta\beta$, reactor, atmospheric, short-baseline ... (absolute mass, sterile neutrinos, Majorana nature, mass hierarchy...)

$$\begin{pmatrix} \nu_e \\ \nu_\mu \\ \nu_\tau \end{pmatrix} = \begin{pmatrix} U_{e1} & U_{e2} & U_{e3} \\ U_{\mu1} & U_{\mu2} & U_{\mu3} \\ U_{\tau1} & U_{\tau2} & U_{\tau3} \end{pmatrix} \begin{pmatrix} \nu_1 \\ \nu_2 \\ \nu_3 \end{pmatrix}$$

$$\begin{pmatrix} U_{e1} & U_{e2} & U_{e3} \\ U_{\mu1} & U_{\mu2} & U_{\mu3} \\ U_{\tau1} & U_{\tau2} & U_{\tau3} \end{pmatrix} = \begin{pmatrix} 1 & 0 & 0 \\ 0 & c_{23} & s_{23} \\ 0 & -s_{23} & c_{23} \end{pmatrix} \times \begin{pmatrix} c_{13} & 0 & s_{13}e^{-i\delta} \\ 0 & 1 & 0 \\ -s_{13}e^{-i\delta} & 0 & c_{13} \end{pmatrix} \times \begin{pmatrix} c_{12} & s_{12} & 0 \\ -s_{12} & c_{12} & 0 \\ 0 & 0 & 1 \end{pmatrix}$$

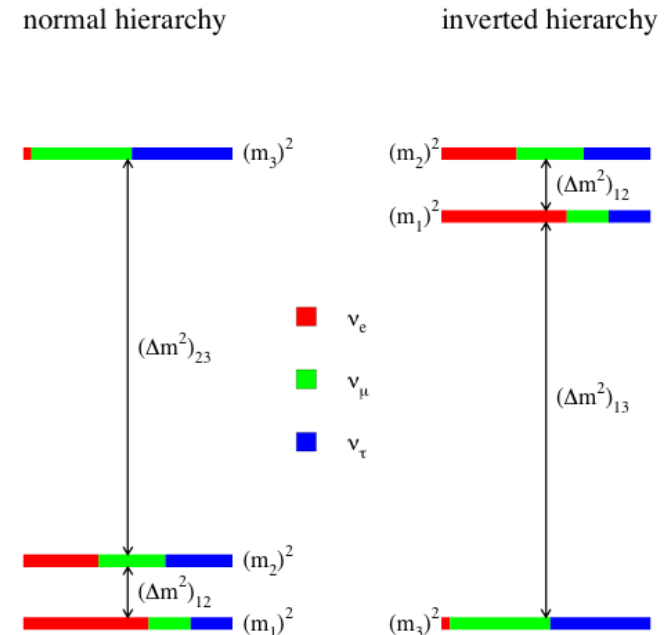

Three long-baseline options were considered for the European Strategy discussions

HyperK (Japan)

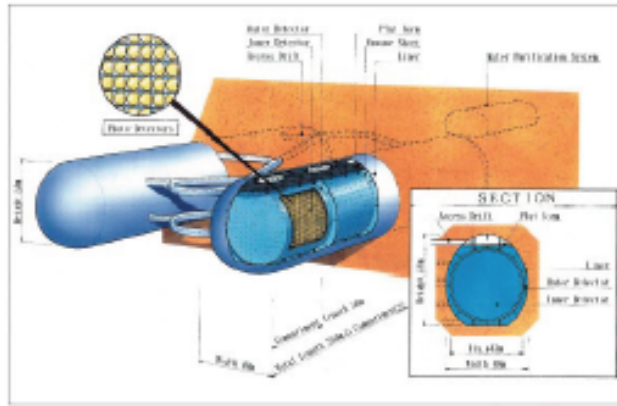

750 kW , 560kton WC, Tokai-Kamioka (295km)

LBNE (USA)

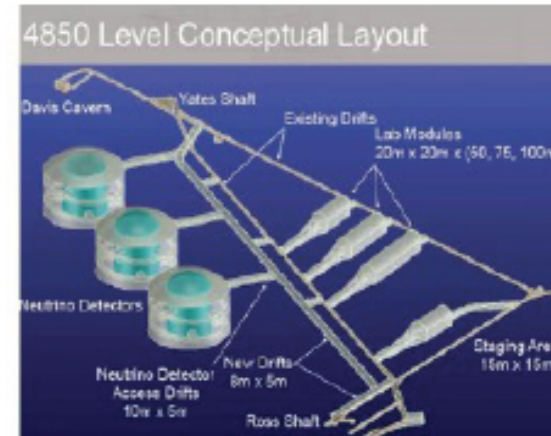

800 kW , 10kton-> 35kton LAr, Fermilab-Homestake(1300km)

LBNO (Europe)

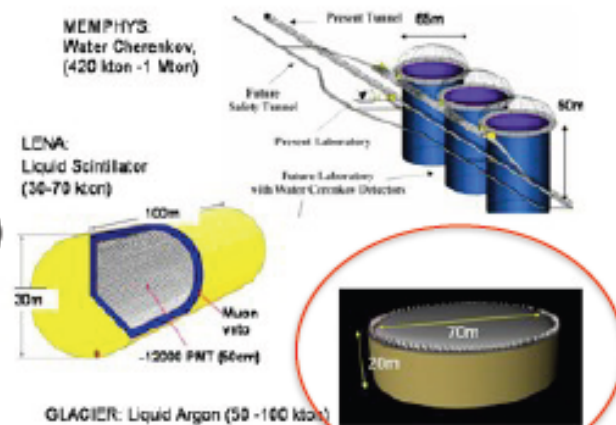

800 kW 20kton-> 100kton LAr, CERN-Pyhäsalmi (2300km)

From P. Hernandez

Long-baseline neutrino experiments

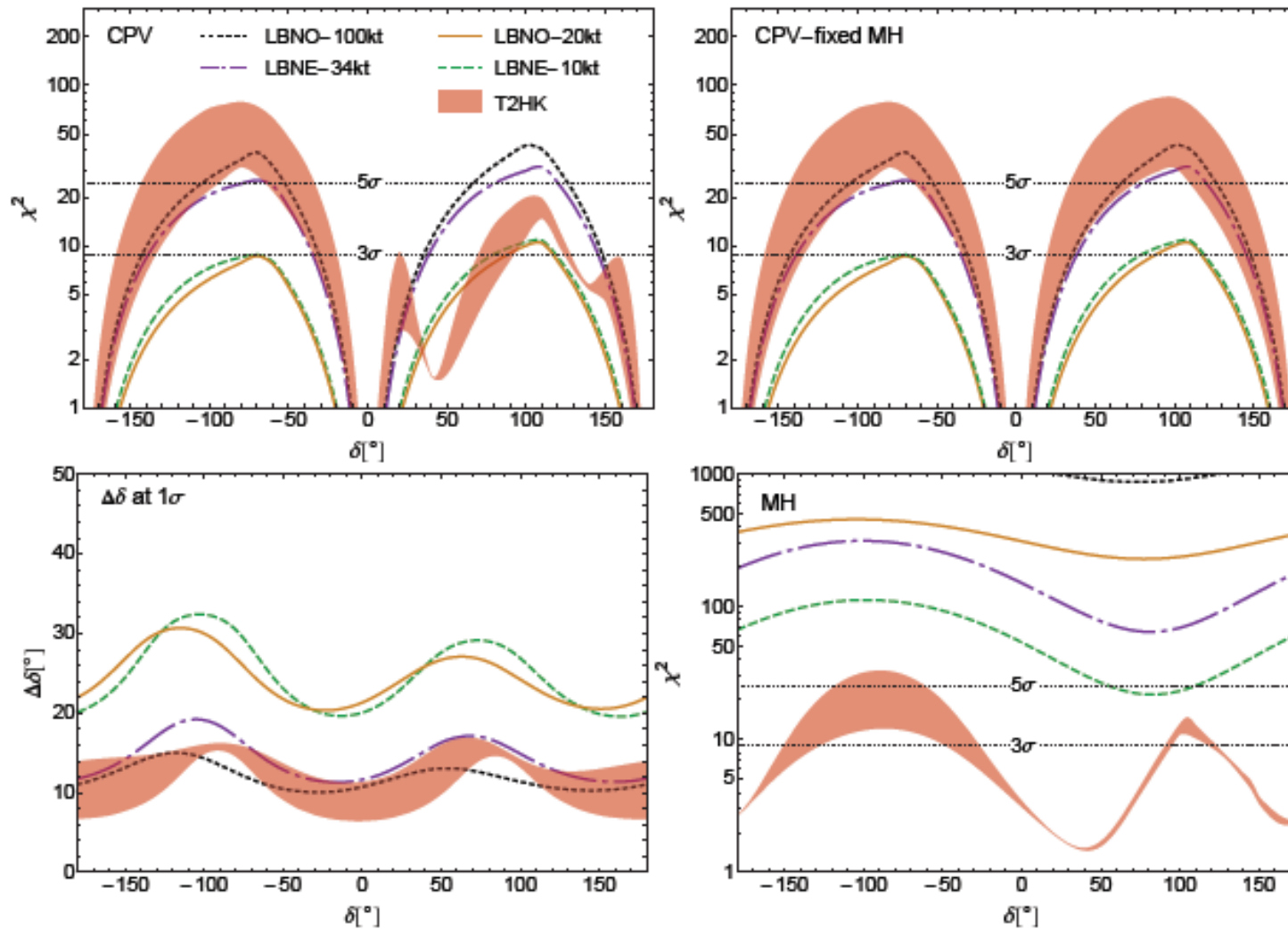

CP violating phase δ
 Mass Hierarchy (sign of Δm^2_{31})

(LBNO, LBNE for 10y, T2HK for 5y)

Flavour and Symmetry



(Paintings of Kabuki actors)

Summary

- There has been substantial recent progress in flavour physics since 2006.
 - B factories (both Belle and BaBar), high PT physics (CDF, D0, ATLAS and CMS) and LHCb
 - NA62 for kaons, and MEG for muon CLFV.
- The success of the SM in flavour physics excludes new physics sources in the flavour breaking sector at the TeV energy scale.
- With high intensity/luminosity facilities, future experiments would find deviations from the SM, and hints for new physics.
 - The key approach is to push forward the precision in the cleanest observables.
- Flavour physics is complementary to high-energy/high-PT physics, and also complementary amongst themselves.
- Flavour physics is required to understand new physics beyond the SM.

*From 'Physics of Flavour and Symmetry'
presented by Yoshitaka Kuno at the ES Erice*

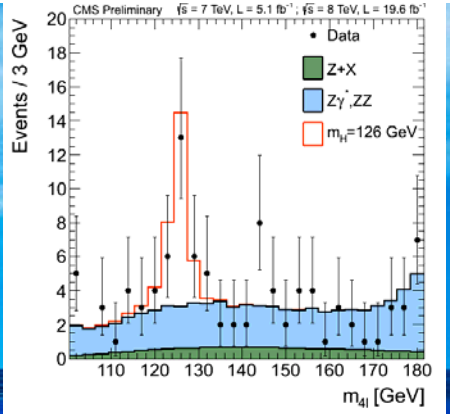
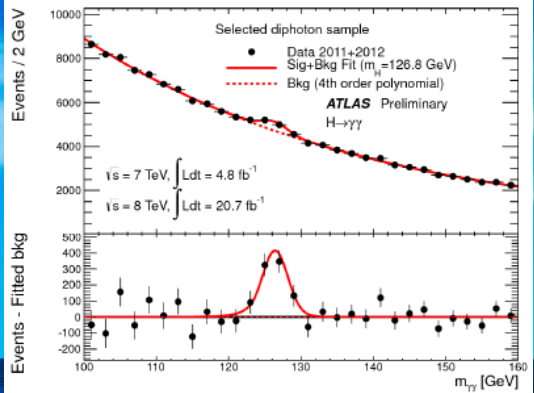

The High Energy Frontier

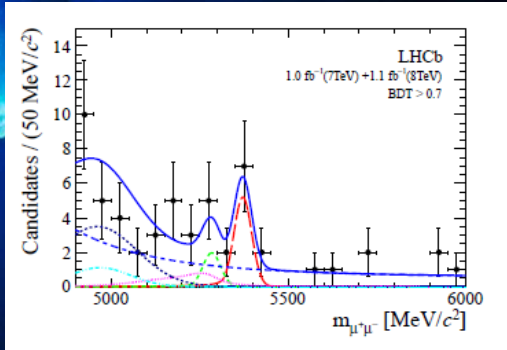
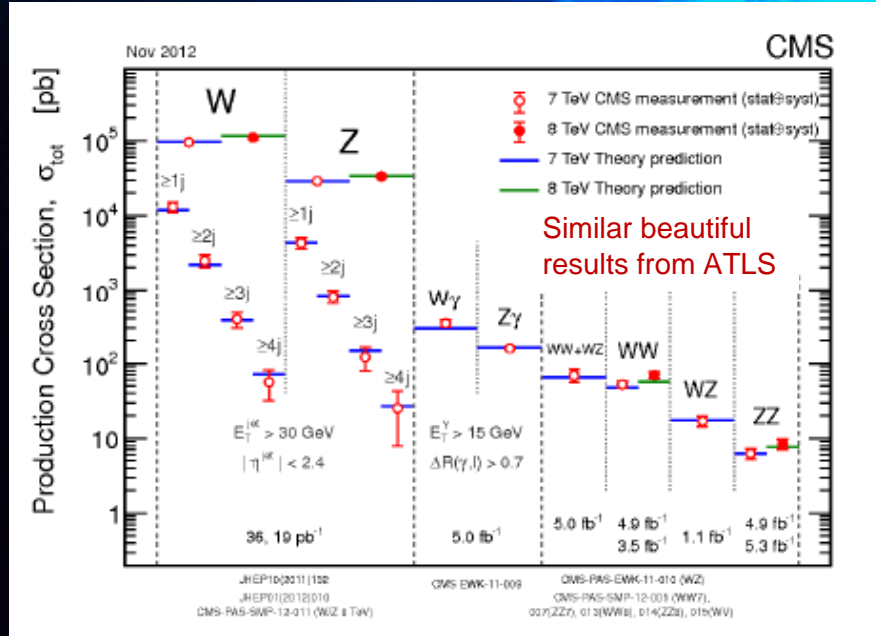

Latsis, Zurich, 5 June 2013
P Jenni, Freiburg and CERN

High Energy Frontier

©Ralph A. Clevenger/CORBIS
17

Collider options for the high energy frontier

pp colliders

	Years	E_{cm} TeV	Luminosity $10^{34} \text{cm}^{-2} \text{s}^{-1}$	Int. Luminosity fb^{-1}
Design LHC	2014-21	14	1-2	300
HL-LHC	2024-30	14	5	3000
HE-LHC	>2035	26-33*	2	100-300/y
V-LHC**	>2035	42-100		

* 16-20 T dipole field
** 80 km Tunnel

e+e- colliders

	Years	E_{cm} GeV	Luminosity $10^{34} \text{cm}^{-2} \text{s}^{-1}$	Tunnel length km
ILC 250	<2030	250	0.75	
ILC 500		500	1.8	~30
ILC 1000		1000		~50
CLIC 500	>2030	500	2.3(1.3)	~13
CLIC 1400		1400(1500)	3.2(3.7)	~27
CLIC 3000		3000	5.9	~48
LEP3	>2024	240	1	LEP/LHC ring
TLEP	>2030	240	5	80 (ring)
TLEP		350	0.65	80 (ring)

Other options:

$\mu^+\mu^-$ and $\gamma\gamma$ colliders
with similar physics as
 e^+e^- colliders

LHeC for ep collisions

See ES Briefing Book for references

LHC

Nominal design performance
(dots: peak luminosity
line: total integrated luminosity)

ES Open Symp. Contr. ID=153

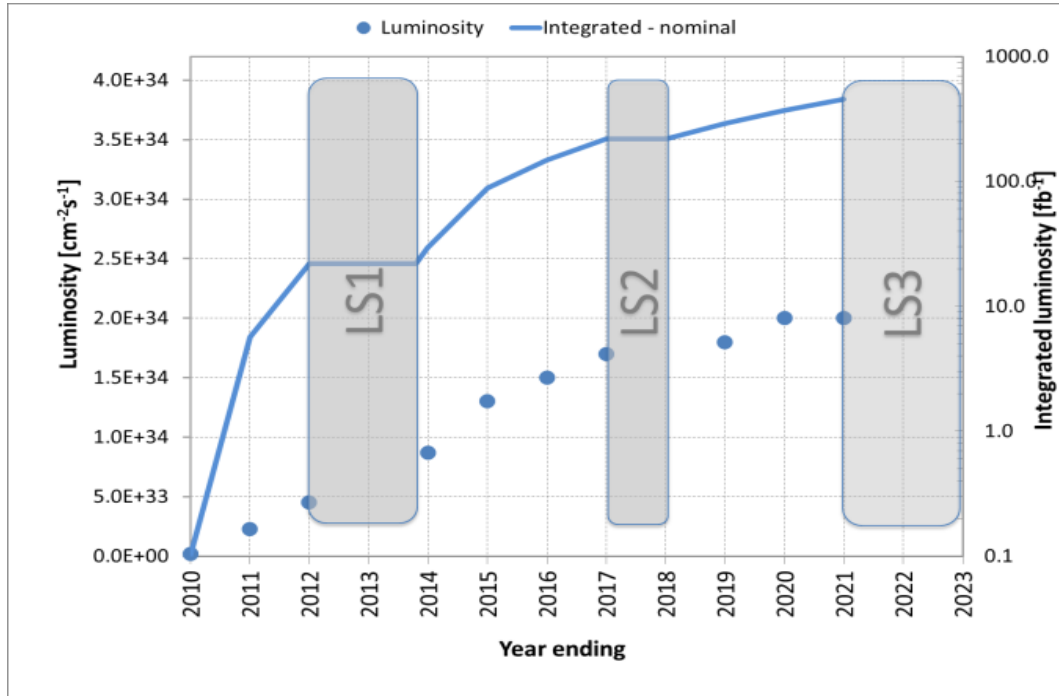

Projected integrated luminosity

Latsis, Zurich, 5 June 2013
P Jenni, Freiburg and CERN

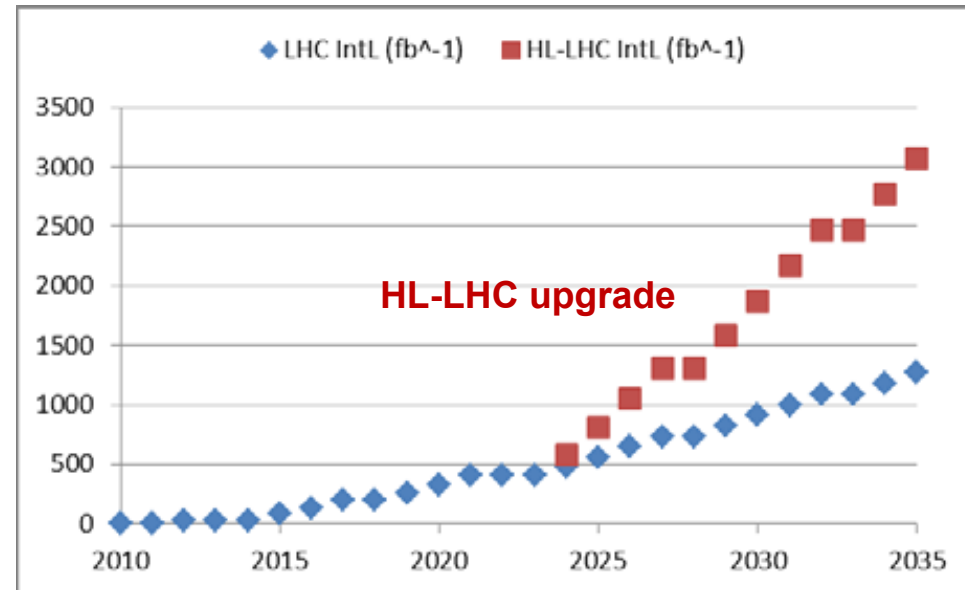

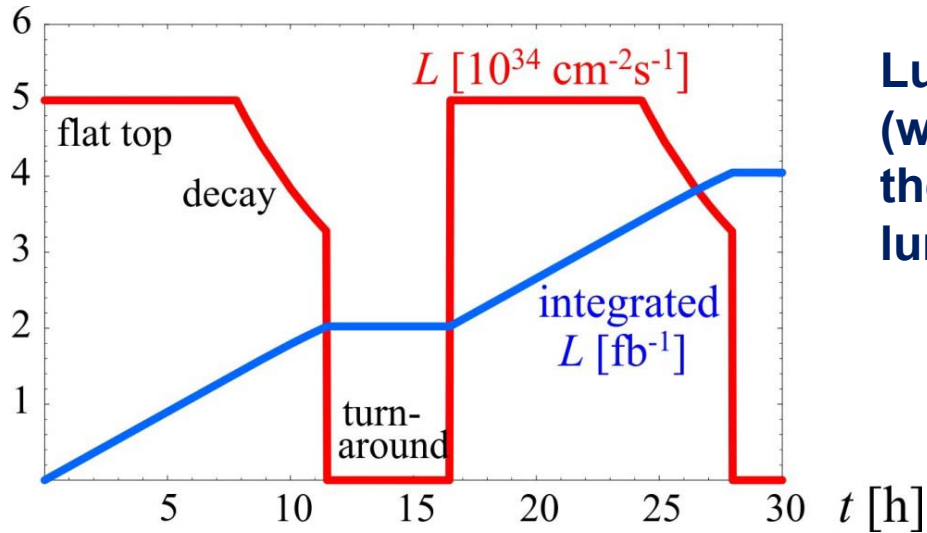

Luminosity cycle for HL-LHC (with 'levelling', optimized for the experiments and integrated luminosity)



Baseline plan for reaching the HL-LHC phase

ES Open Symp. Contr. ID=153

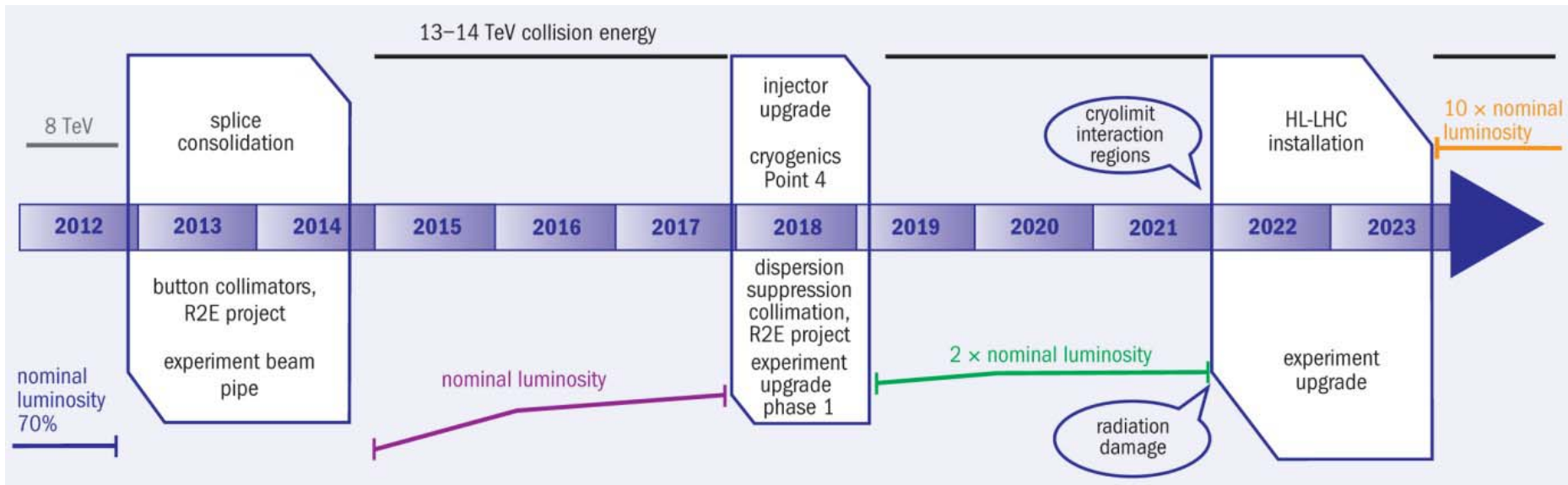

Higher energy hadron colliders

One option, called HE-LHC, would be to install a new collider in the present LHC tunnel, together with a fully upgraded injector chain

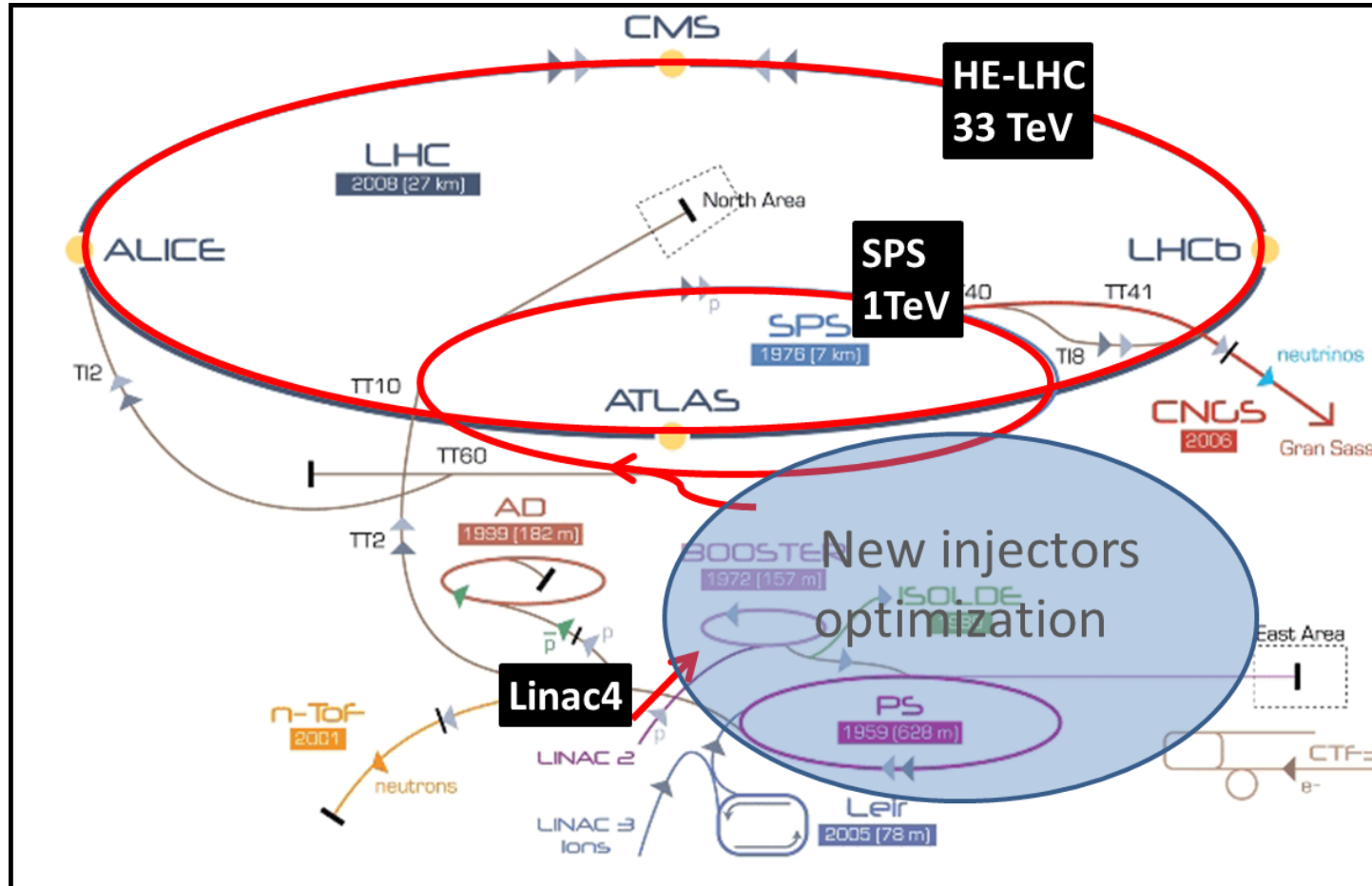

Higher energy hadron colliders require further progress in the developments of high-field magnets

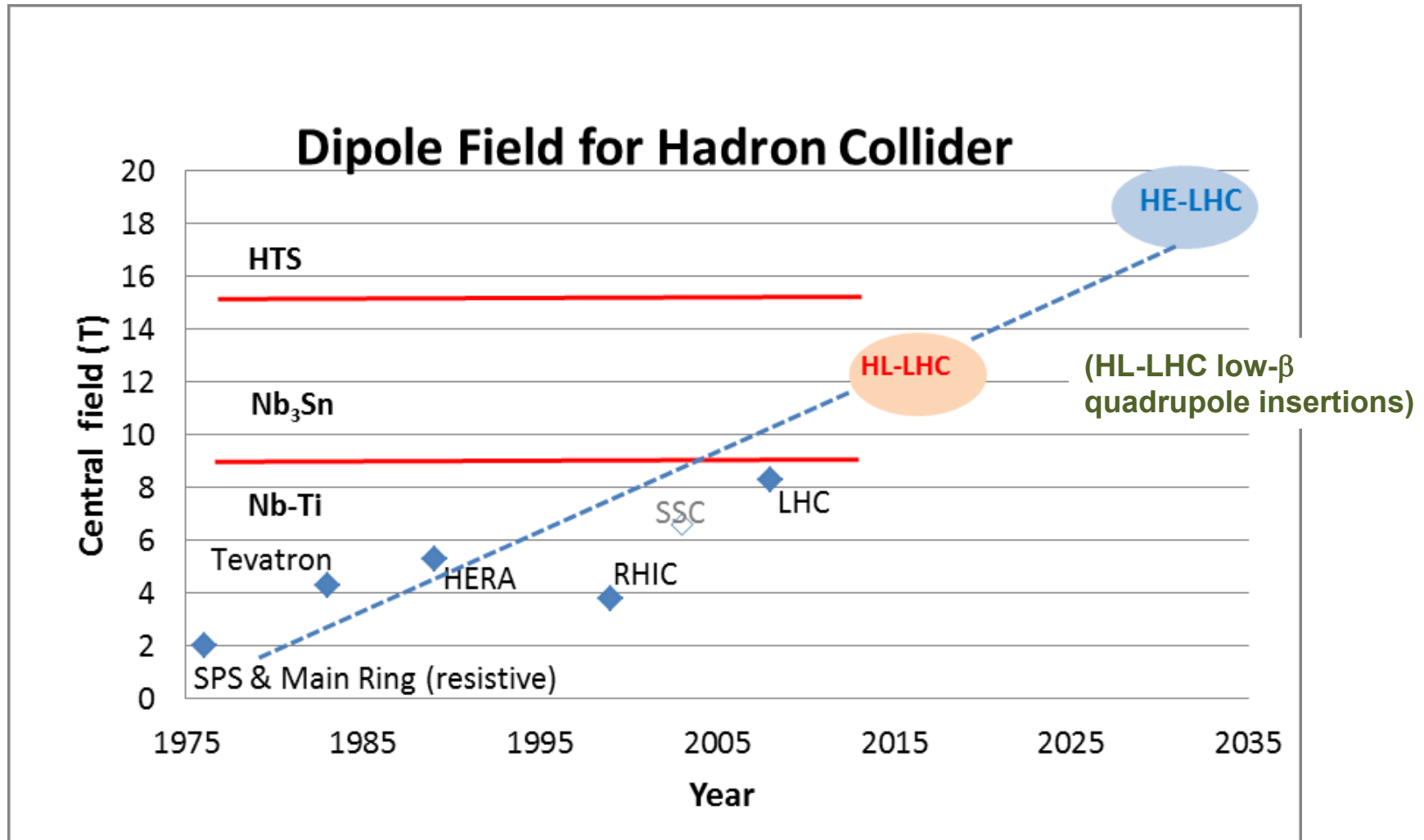

History of high-field magnets for hadron colliders

Latsis, Zurich, 5 June 2013
P Jenni, Freiburg and CERN

High Energy Frontier

CERN-ATS-2012-237
ES Open Symp. Contr. ID=155

First conceptual layout of a 20 Tesla magnet that would fit into the LHC tunnel

L. Rossi and E. Todesco

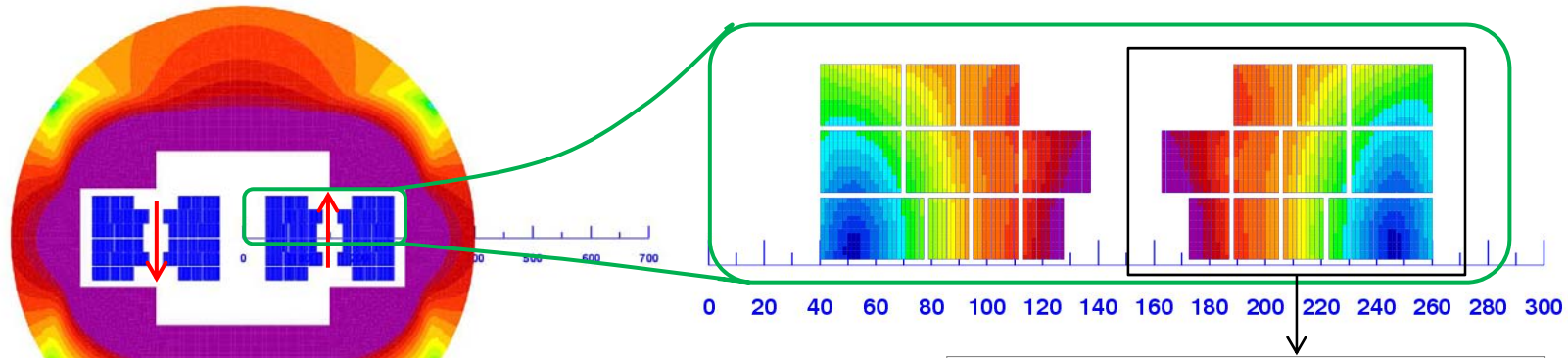

Material	N. turns	Coil fraction	Peak field	J_{overall} (A/mm ²)
Nb-Ti	41	27%	8	380
Nb3Sn (high Jc)	55	37%	13	380
Nb3Sn (Low Jc)	30	20%	15	190
HTS	24	16%	20.5	380

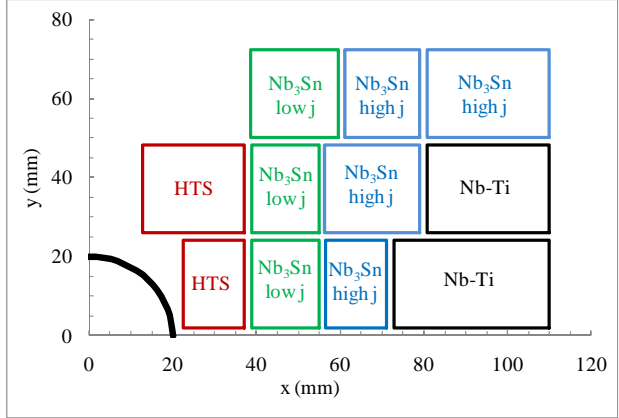

Magnet design: 40 mm bore (depends on injection energy: > 1 Tev)
Very challenging but feasible: 300 mm inter-beam; anticoincidence to reduce flux
Approximately 2.5 times more SC than LHC: 3000 tonnes!
Multiple powering in the same magnet for FQ (and more sectioning for energy)
Certainly only a first attempt: cos θ and other shapes will be also investigated

It took a long time to develop the magnets for LHC...

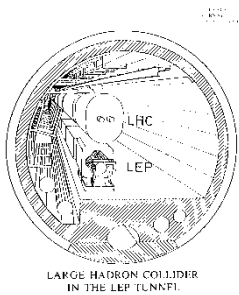
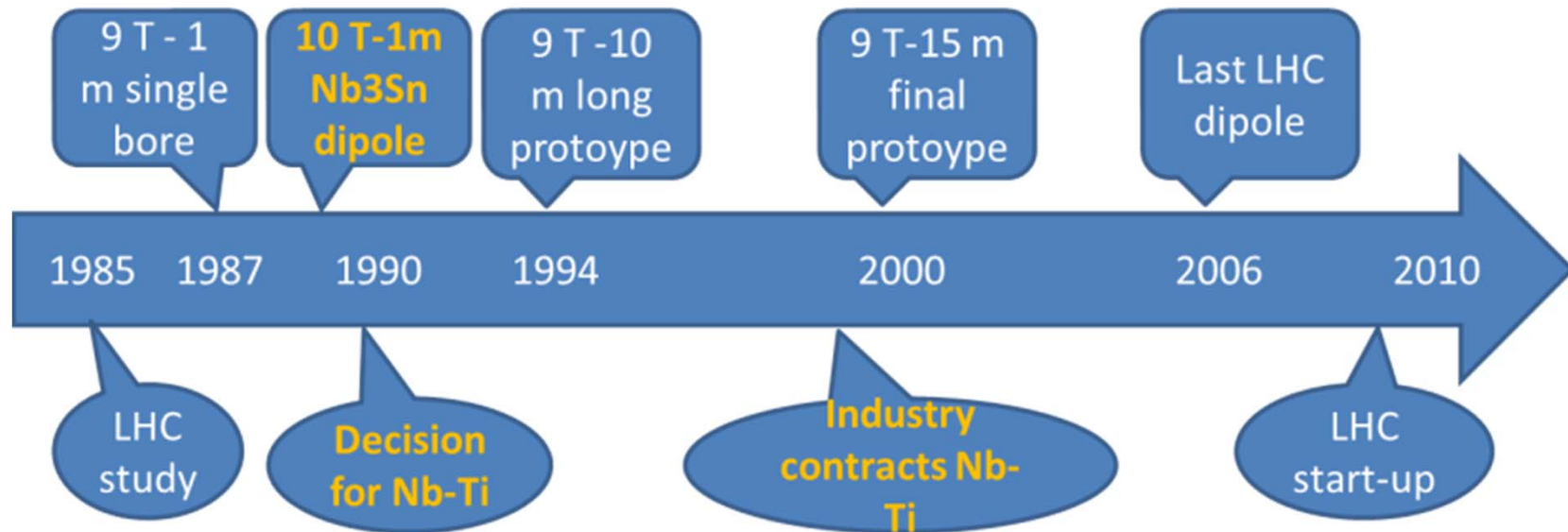

... so an intense R&D programme is required to continue rigorously now if HE-LHC should become a real option for following the HL-LHC in the 2030s

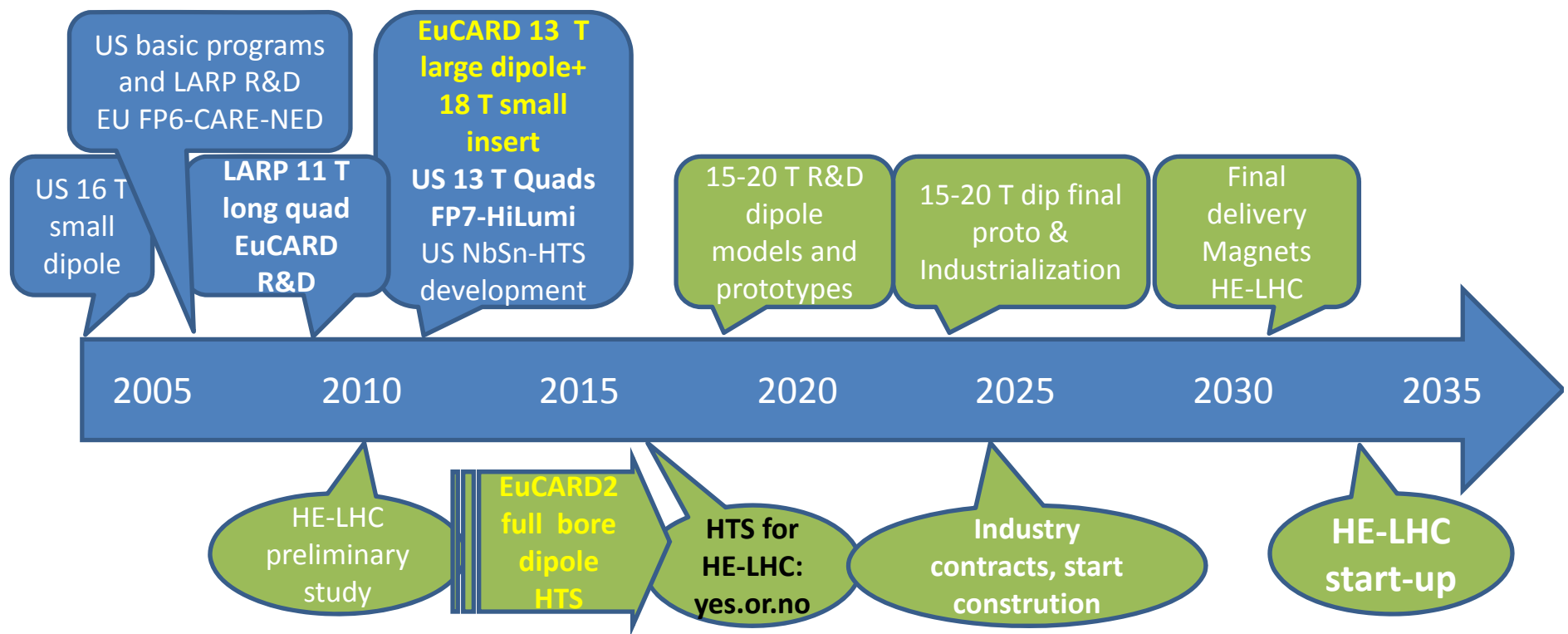

HL-LHC work as a test bed

High Energy Frontier

From L. Rossi, CERN

Looking further ahead, options for a new ring tunnel

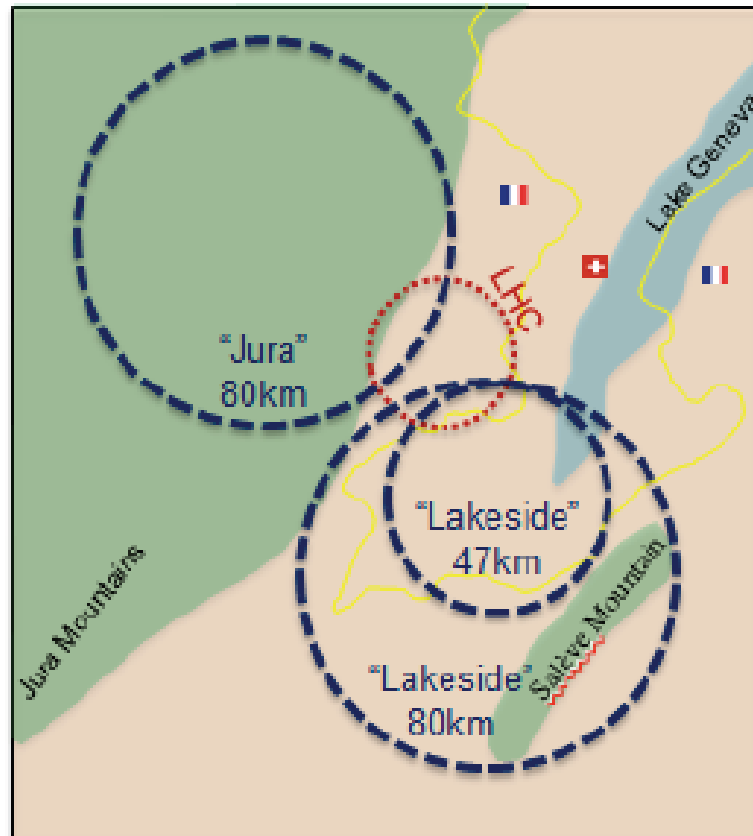

■ Molasse ■ Limestone

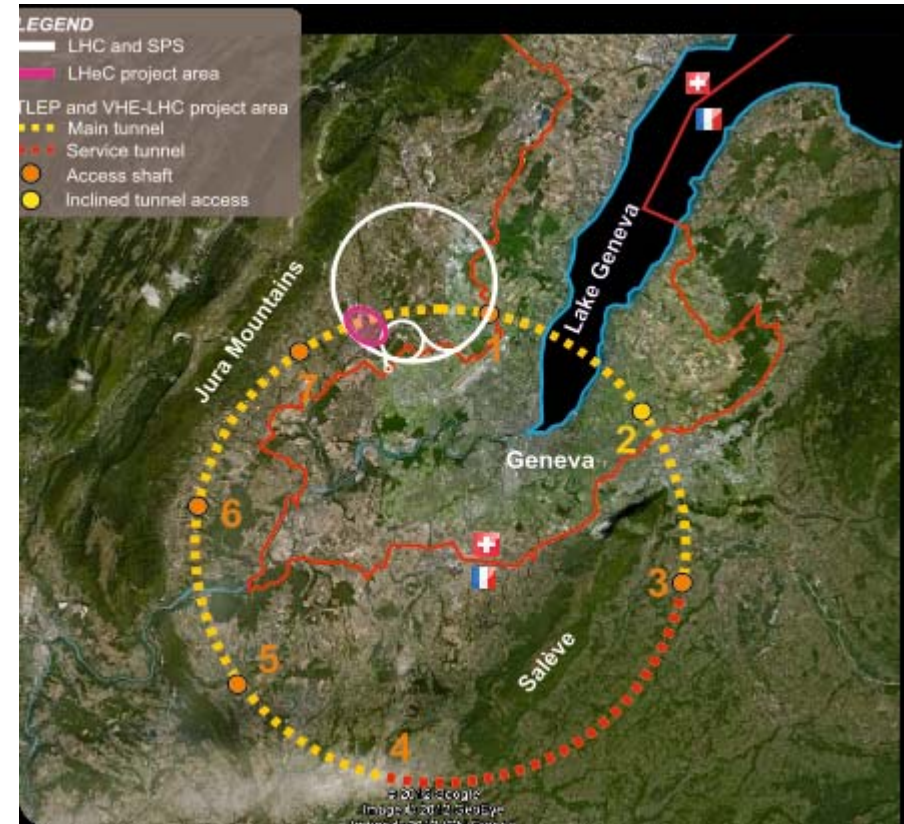

Lake-side option kept for further studies

*Pre-Feasibility Study for an 80-km tunnel at CERN
- John Osborne and Caroline Waaijer*

For a Very High Energy Hadron Collider ranging from 42 TeV (8.3T LHC magnets) to 100 TeV (20T very high field magnets with HTS), and could house first an e^+e^- collider TLEP up to 350 GeV

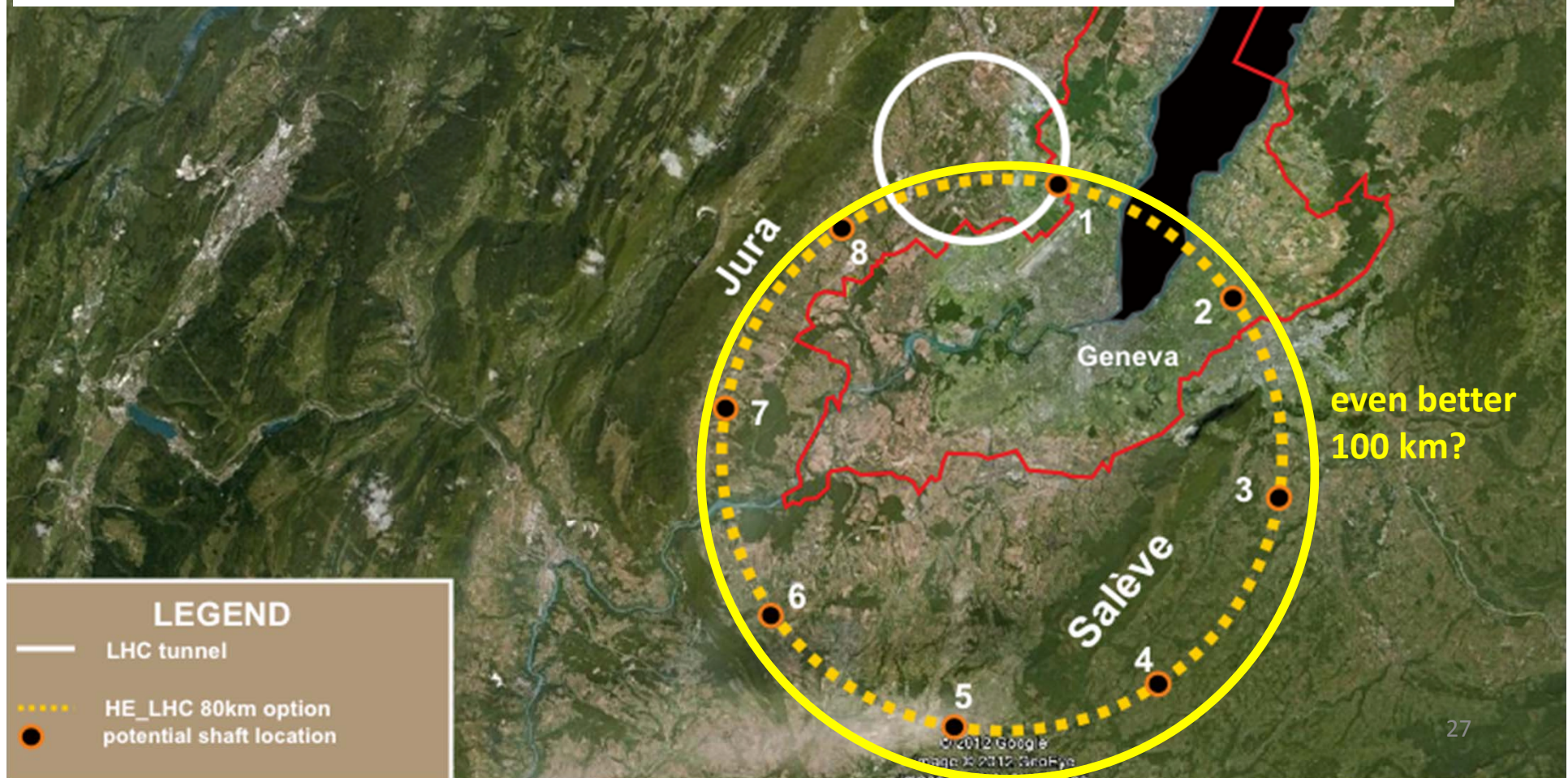

Parameters for the hadron collider ‘family’ at CERN

Parameter	LHC	HL-LHC		HE-LHC	VHE-LHC
c.m. energy [TeV]		14		33	100
circumference C [km]		26.7			80
dipole field [T]		8.33		20	20
dipole coil aperture [mm]		56		40	≤ 40
beam half aperture [cm]		2.2 (x), 1.8 (y)		1.3	< 1.3
injection energy [TeV]		0.45		>1.0	>3.0
no. of bunches	2808	2808	1404	2808	8420
bunch population [10^{11}]	1.125	2.2	3.5	0.81	0.80
init. transv. norm. emit. [μm]	3.73,	2.5	3.0	1.07	1.70
initial longitudinal emit. [eVs]		2.5		3.48	13.6
no. IPs contributing to tune shift	3	2	2	2	2
max. total beam-beam tune shift	0.01	0.021	0.028	0.01	0.01
beam circulating current [A]	0.584	1.12	0.089	0.412	0.401
RF voltage [MV]		16		16	22
rms bunch length [cm]		7.55		7.55	7.55
IP beta function [m]	0.55	0.73 \rightarrow 0.15		0.3	0.9
init. rms IP spot size [μm]	16.7	15.6 \rightarrow 7.1	24.8 \rightarrow 7.8	4.3	5.3

Stored energy [MJ]

362

694

601

4573

Peak luminosity [$10^{34} \text{ cm}^{-2}\text{s}^{-1}$]

1

(7.4)

5

5

O.Dominguez, L.Rossi, F.Zimmermann

Collider options for the high energy frontier

pp colliders

	Years	E_{cm} TeV	Luminosity $10^{34} \text{cm}^{-2} \text{s}^{-1}$	Int. Luminosity fb^{-1}
Design LHC	2014-21	14	1-2	300
HL-LHC	2024-30	14	5	3000
HE-LHC	>2035	26-33*	2	100-300/y
V-LHC**	>2035	42-100		

* 16-20 T dipole field

** 80 km Tunnel

e+e- colliders

	Years	E_{cm} GeV	Luminosity $10^{34} \text{cm}^{-2} \text{s}^{-1}$	Tunnel length km
ILC 250	<2030	250	0.75	
ILC 500		500	1.8	~30
ILC 1000		1000		~50
CLIC 500	>2030	500	2.3(1.3)	~13
CLIC 1400		1400(1500)	3.2(3.7)	~27
CLIC 3000		3000	5.9	~48
LEP3	>2024	240	1	LEP/LHC ring
TLEP	>2030	240	5	80 (ring)
TLEP		350	0.65	80 (ring)

Other options:

$\mu^+\mu^-$ and $\gamma\gamma$ colliders
with similar physics as
 e^+e^- colliders

LHeC for ep collisions

See ES Briefing Book for references

Mature detailed TDR studies based on extensive R&D

Industrial production of cavities (established for XFEL)

Major Japanese community initiative to host ILC as a global project, site decision for the proposal to be decided in July 2013

Goal to start data taking before 2030

Baseline 250 → 500 GeV (upgradeable to 1 TeV)

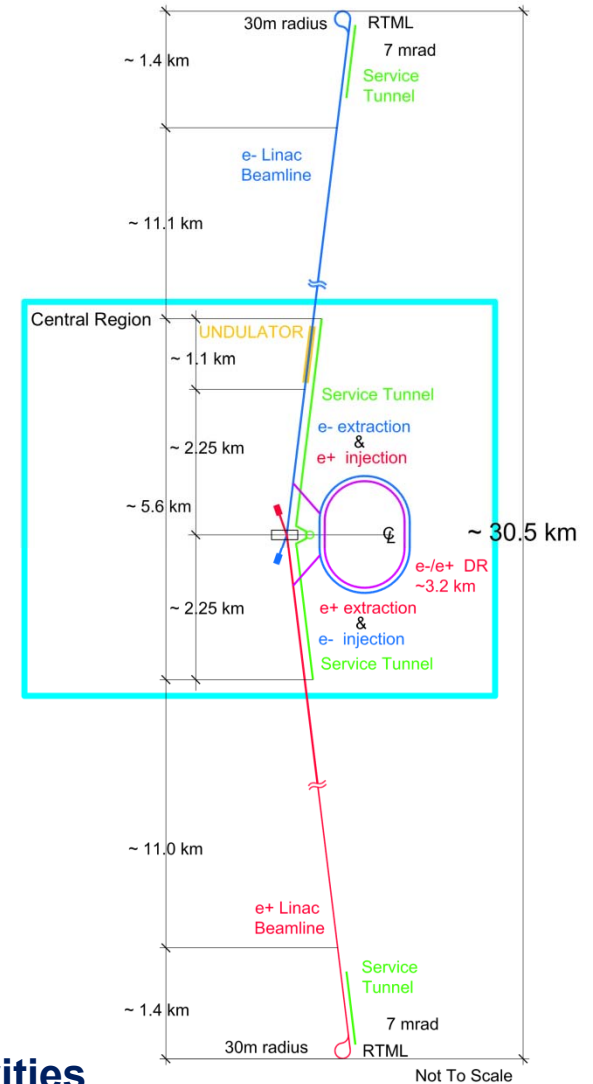
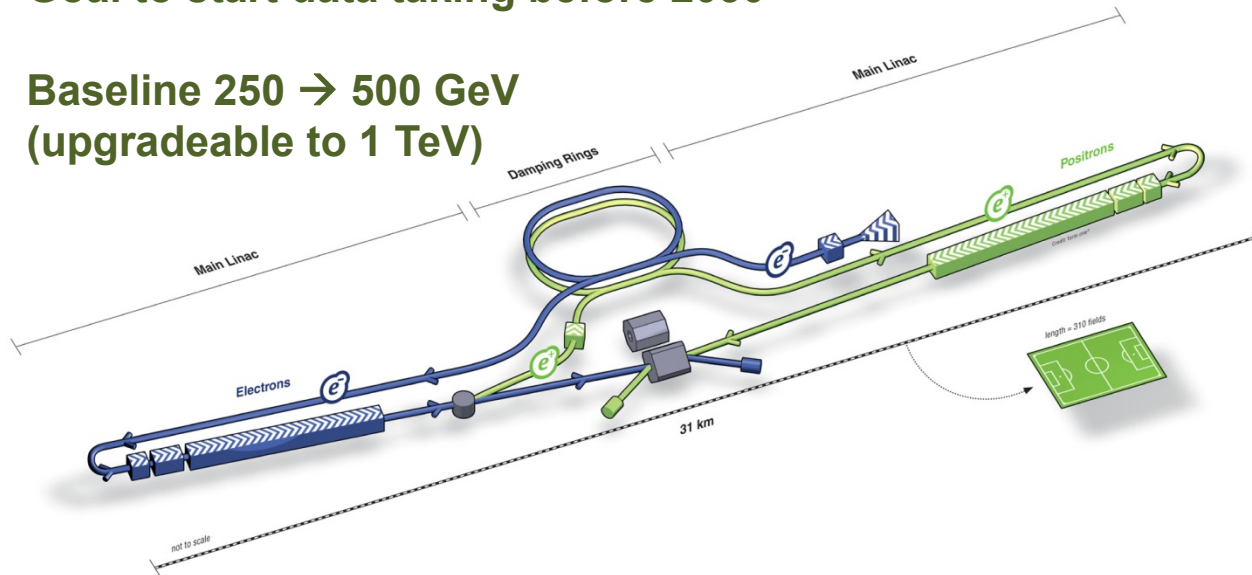

Two single beam linacs with 40 MV/m superconducting RF cavities

Compact Linear Collider CLIC



Detailed CDR studies based on extensive R&D

Prove of principle of the two-beam acceleration

ES Open Symp. Contr. ID=99

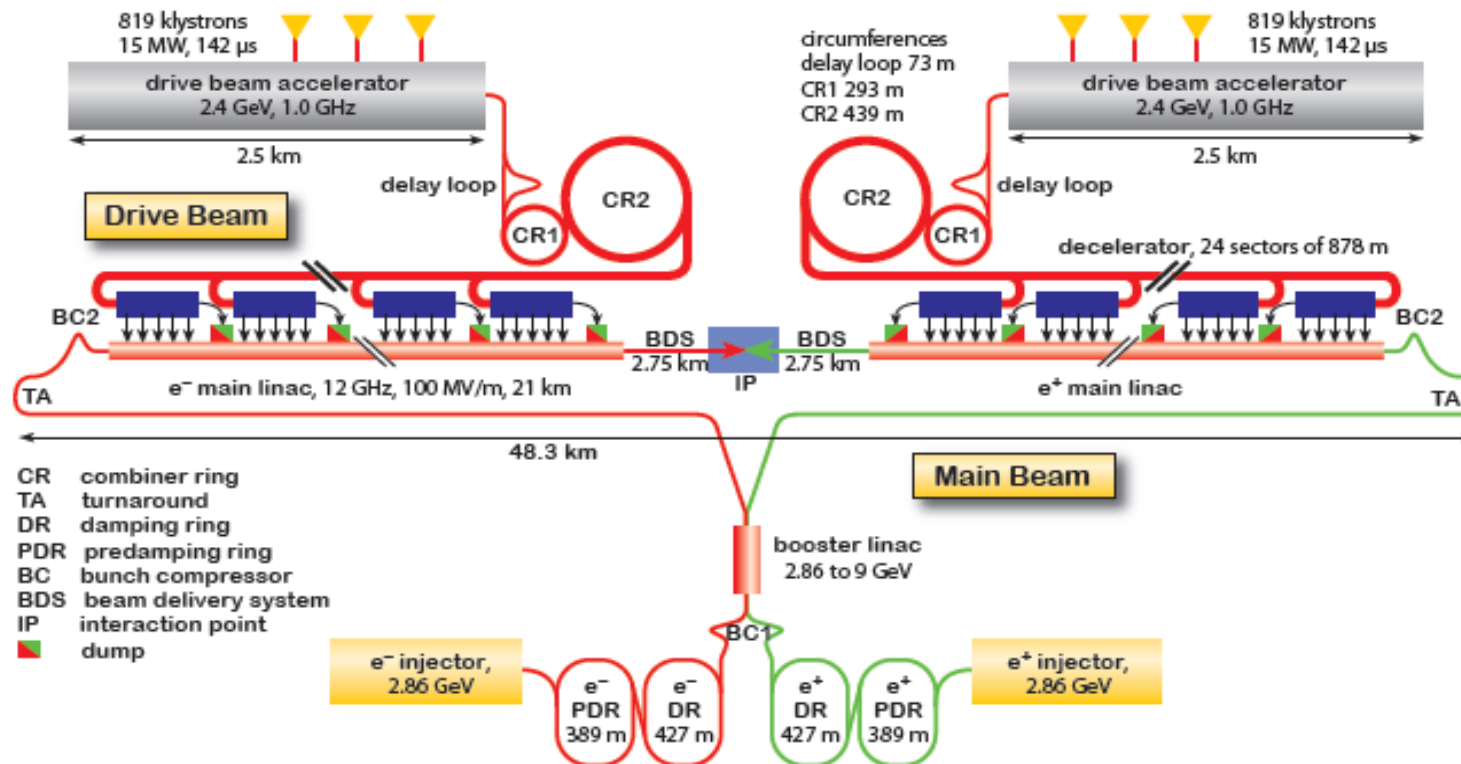

Two-beam acceleration system with a low energy high current drive beam powering the RF cavities at 100 MV/m of the main linac, energy upgradable in stages 500 – 3000 GeV

Common organization within the Linear Collider Collaboration has been set in place recently



Organization

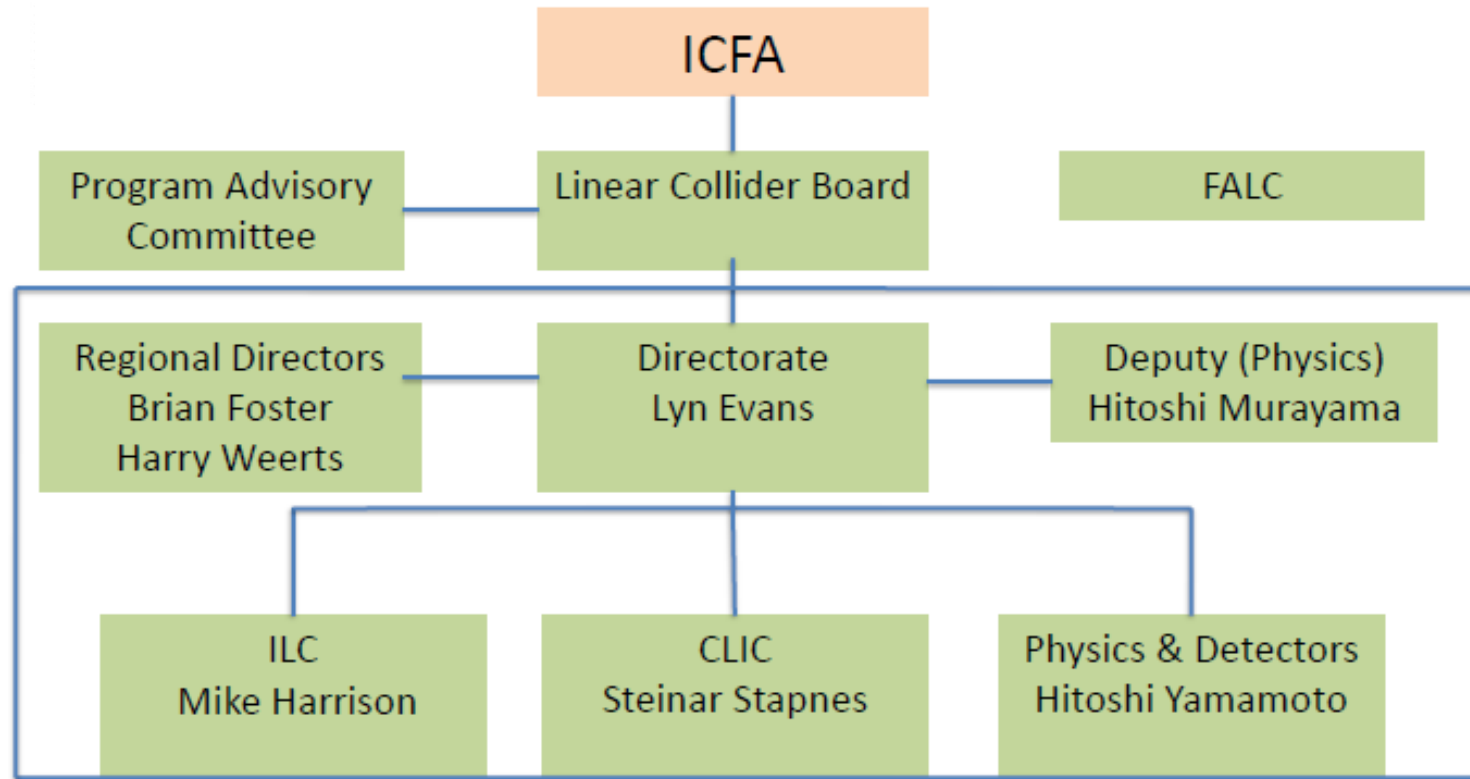

Indicating the Scale for Liner Colliders

(Taken from C. Biscari, 'High Energy Accelerators', Krakow ES Symposium)

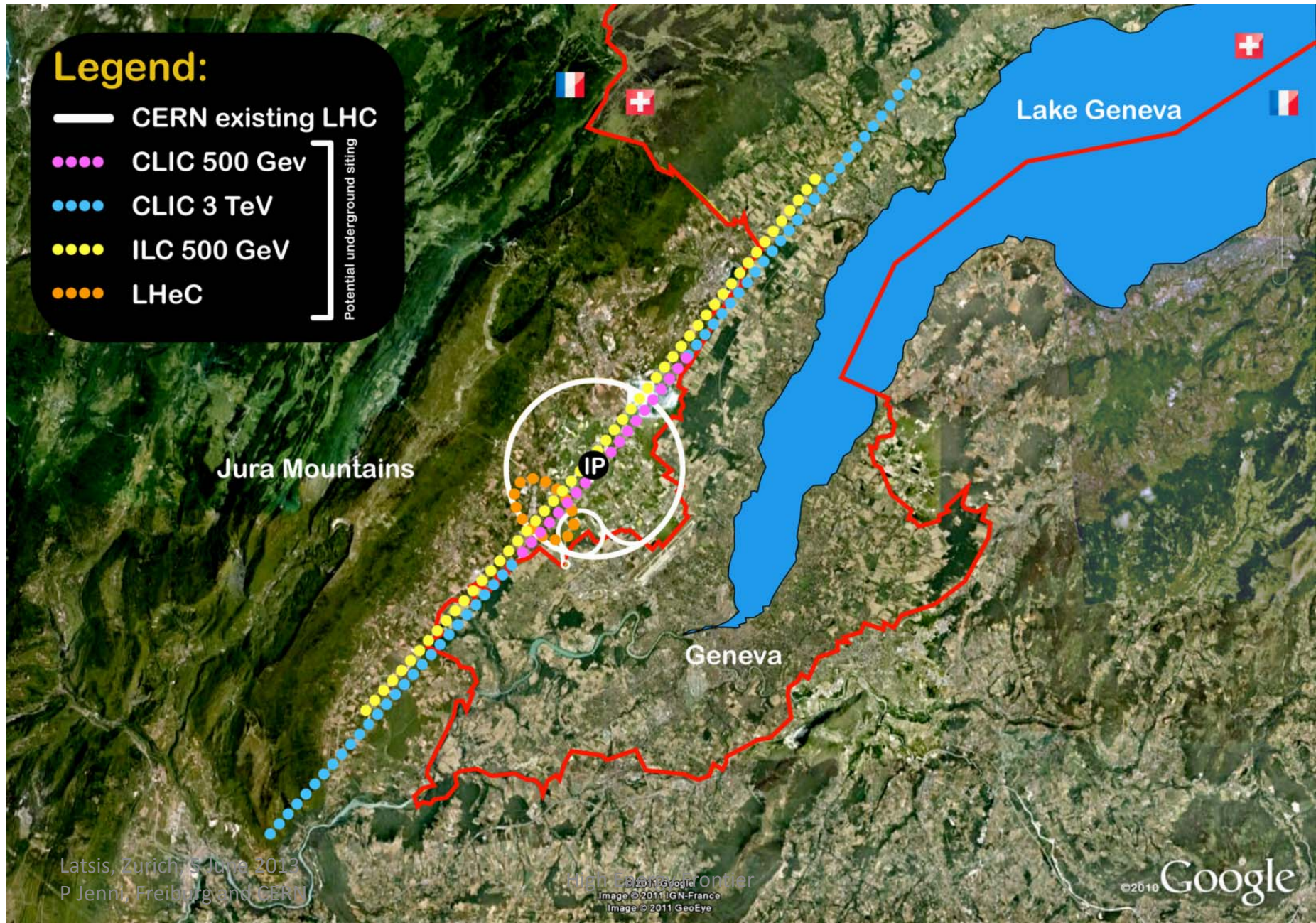

Circular e+e- Colliders

Strong revival of interest in ‘conventional’ Circular Colliders:

- **Very high luminosities achievable**
- **More than one experiment**

LEP3: 240 GeV machine in the LHC tunnel

TLEP: 350 GeV machine in a new 80 km tunnel

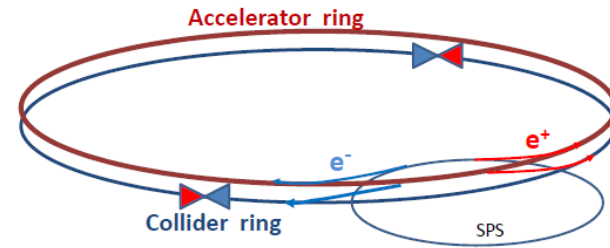

	LEP3	TLEP
circumference	26.7 km	80 km
max beam energy	120 GeV	175 GeV
max no. of IPs	4	4
luminosity at 350 GeV c.m.	-	$0.7 \times 10^{34} \text{ cm}^{-2} \text{ s}^{-1}$
luminosity at 240 GeV c.m.	$10^{34} \text{ cm}^{-2} \text{ s}^{-1}$	$5 \times 10^{34} \text{ cm}^{-2} \text{ s}^{-1}$
luminosity at 160 GeV c.m.	$5 \times 10^{34} \text{ cm}^{-2} \text{ s}^{-1}$	$2.5 \times 10^{35} \text{ cm}^{-2} \text{ s}^{-1}$
luminosity at 90 GeV c.m.	$2 \times 10^{35} \text{ cm}^{-2} \text{ s}^{-1}$	$10^{36} \text{ cm}^{-2} \text{ s}^{-1}$

Electron Proton Collider

Detailed CDR has been published

Option of eA collisions

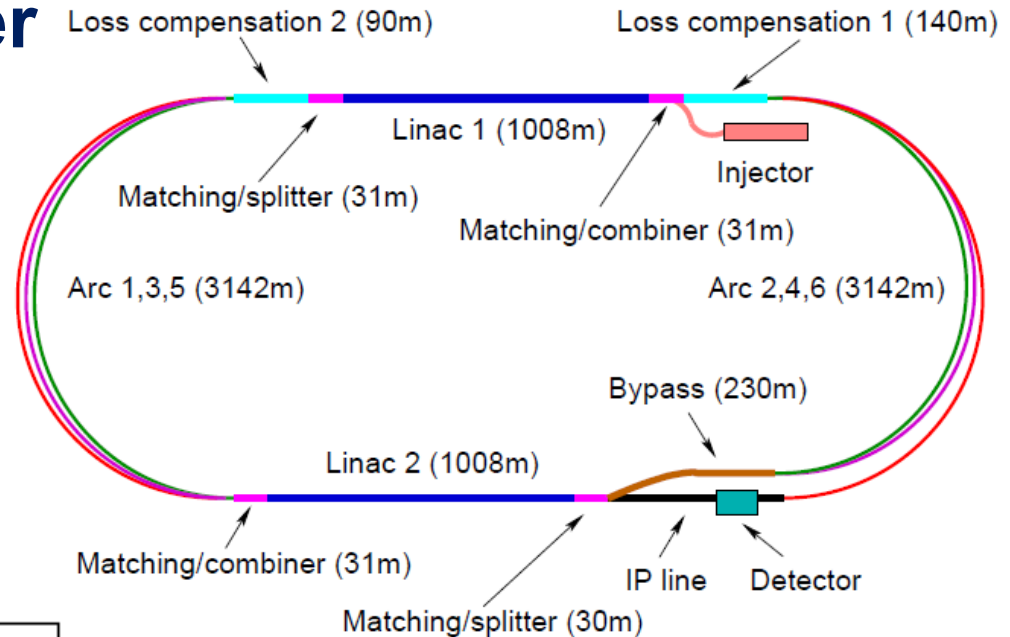

Interaction point 2
(now ALICE) with LHC

Two 10 GeV linac accelerators
in an energy recovery race-track
configuration, three turns giving
60 GeV e⁻ or e⁺

Can reach $Q^2_{max} \sim 1 \text{ TeV}^2$

parameter [unit]	LHeC	
species	e^-	$p, {}^{208}\text{Pb}^{82+}$
beam energy (/nucleon) [GeV]	60	7000, 2760
bunch spacing [ns]	25, 100	25, 100
bunch intensity (nucleon) [10^{10}]	0.1 (0.2), 0.4	17 (22), 2.5
beam current [mA]	6.4 (12.8)	860 (1110), 6
rms bunch length [mm]	0.6	75.5
polarization [%]	90 (e^+ none)	none, none
normalized rms emittance [μm]	50	3.75 (2.0), 1.5
geometric rms emittance [nm]	0.43	0.50 (0.31)
IP beta function $\beta_{x,y}^*$ [m]	0.12 (0.032)	0.1 (0.05)
IP spot size [μm]	7.2 (3.7)	7.2 (3.7)
synchrotron tune Q_s	—	1.9×10^{-3}
hadron beam-beam parameter	0.0001 (0.0002)	
lepton disruption parameter D	6 (30)	
crossing angle	0 (detector-integrated dipole)	
hourglass reduction factor H_{hg}	0.91 (0.67)	
pinch enhancement factor H_D	1.35 (0.3 for e^+)	
CM energy [TeV]	1.3, 0.81	
luminosity / nucleon [$10^{33} \text{ cm}^{-2} \text{ s}^{-1}$]	1 (10), 0.2	

$\gamma\gamma$ collider options

Technology challenge of a high-power laser back-scatter system

CLIC technology based

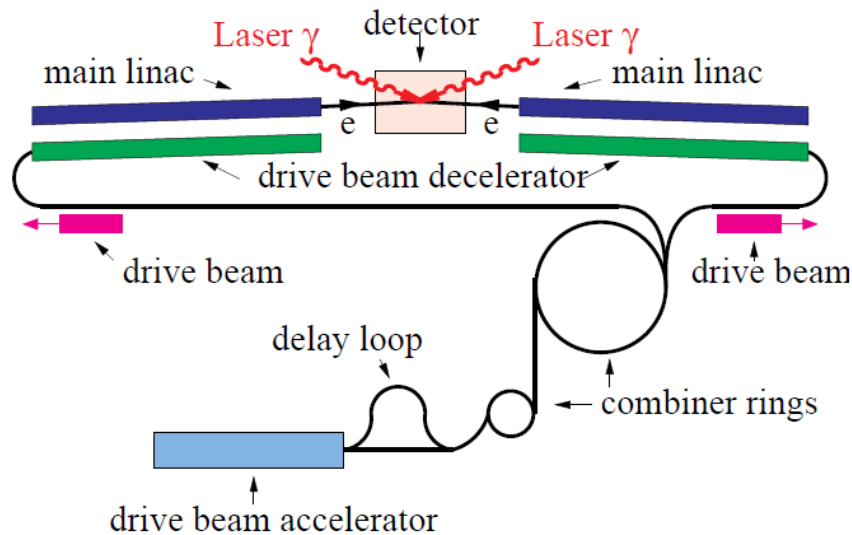

SAPPHiRE 'a small $\gamma\gamma$ Higgs factory'

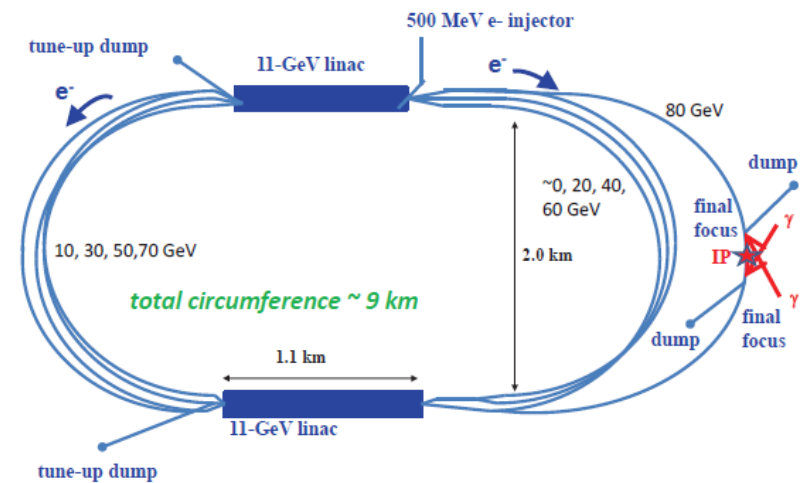

$\gamma\gamma$ collisions at $V_s = 125.5$ GeV (s-channel Higgs production)

Muon Collider / Neutrino Factory



Many technical challenges, interesting potential (s-channel H production)

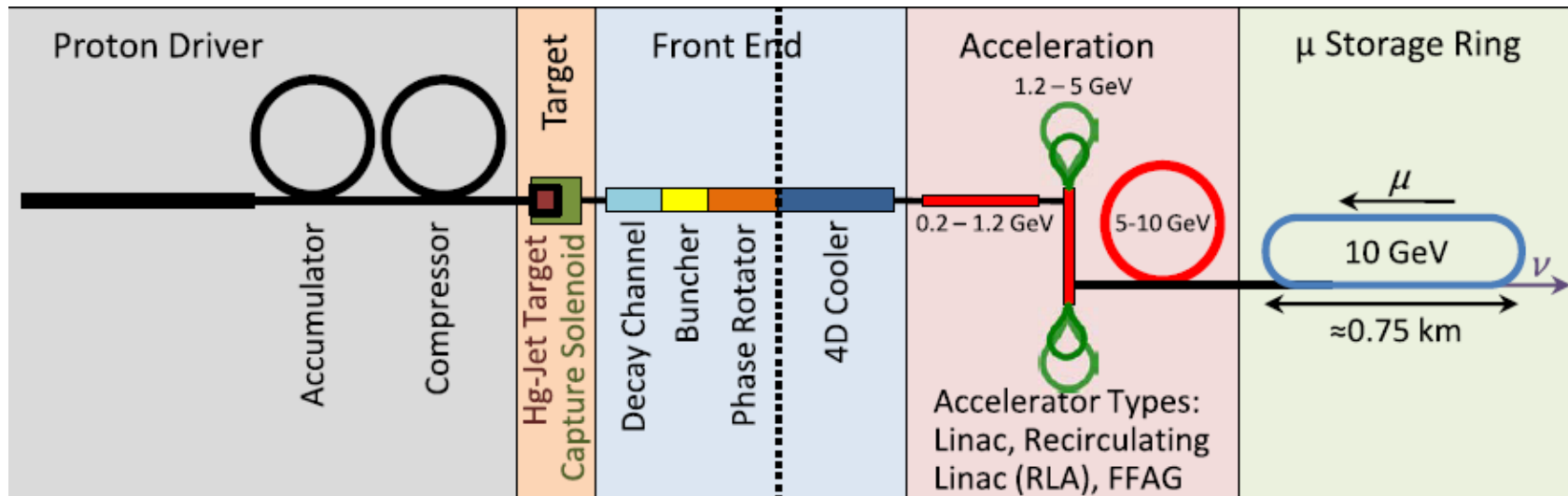
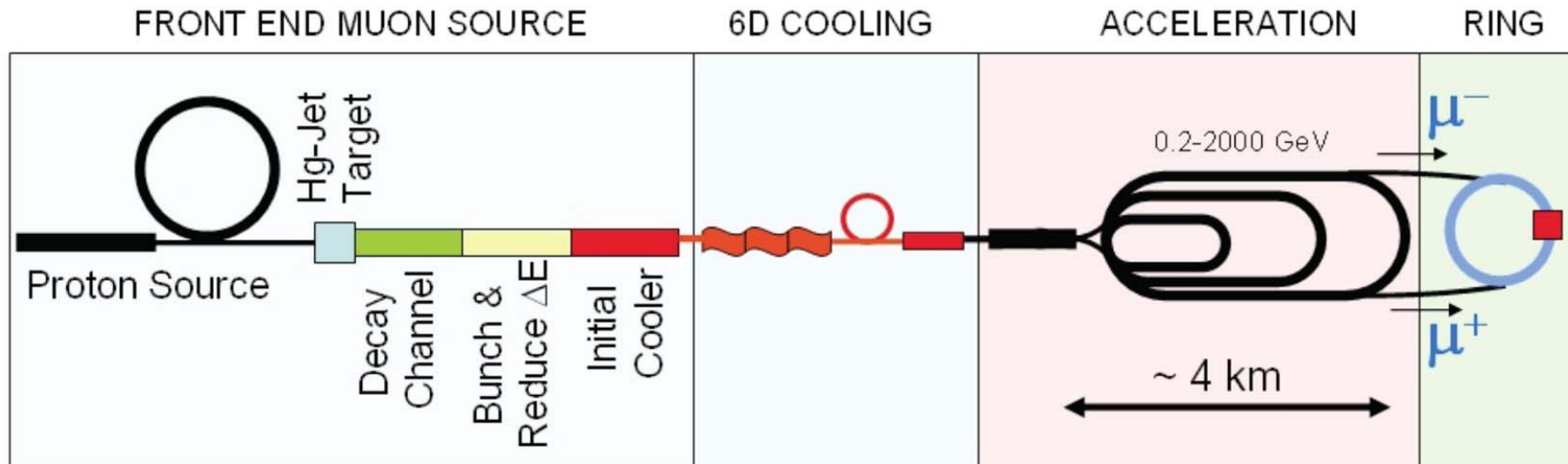

Turning to some physics remarks now ...

But I really refer you to Michelangelo Mangano's very nice talk yesterday!

Hadron colliders are the only realistic option to access very high-mass objects directly, and increasing the collision energy extends the mass reach most strongly

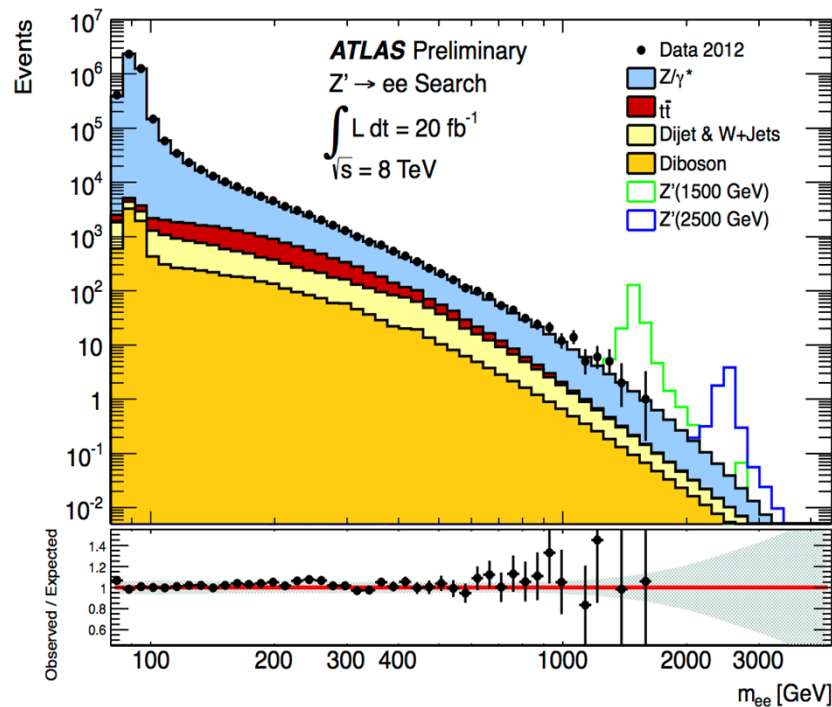

ATLAS-CONF-2013-017

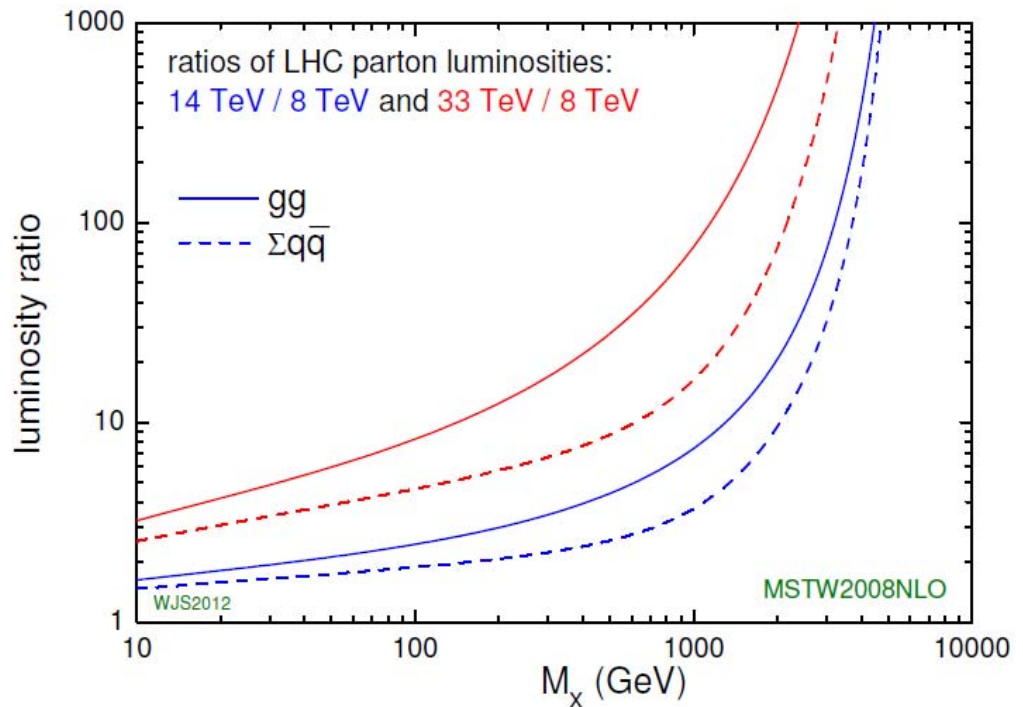

W J Stirling

Turning to some physics remarks now ...

But I really refer you to Michelangelo Mangano's very nice talk yesterday!

Hadron colliders are the only realistic option to access very high-mass objects directly, and increasing the collision energy extends the mass reach most strongly

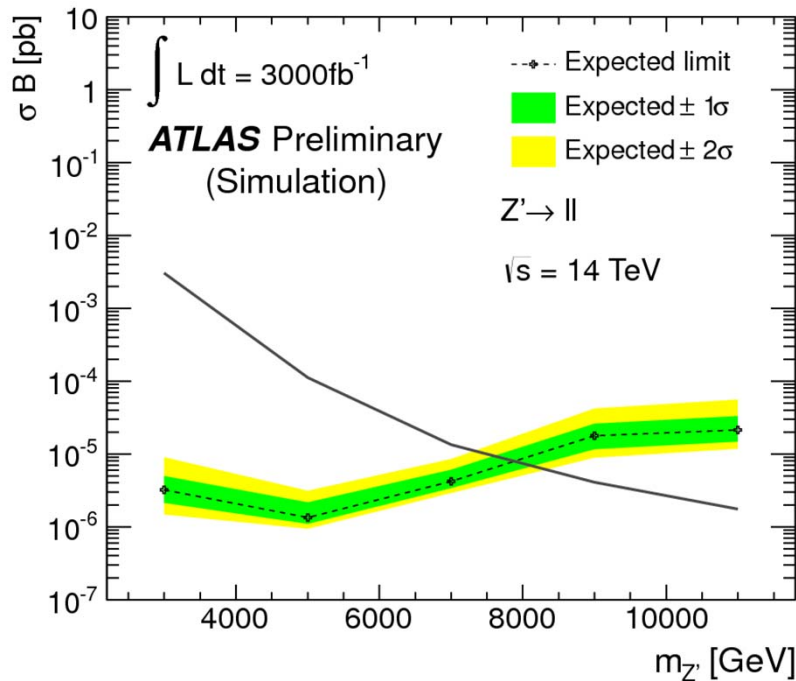

ATLAS-PHYS-PUB-2013-003

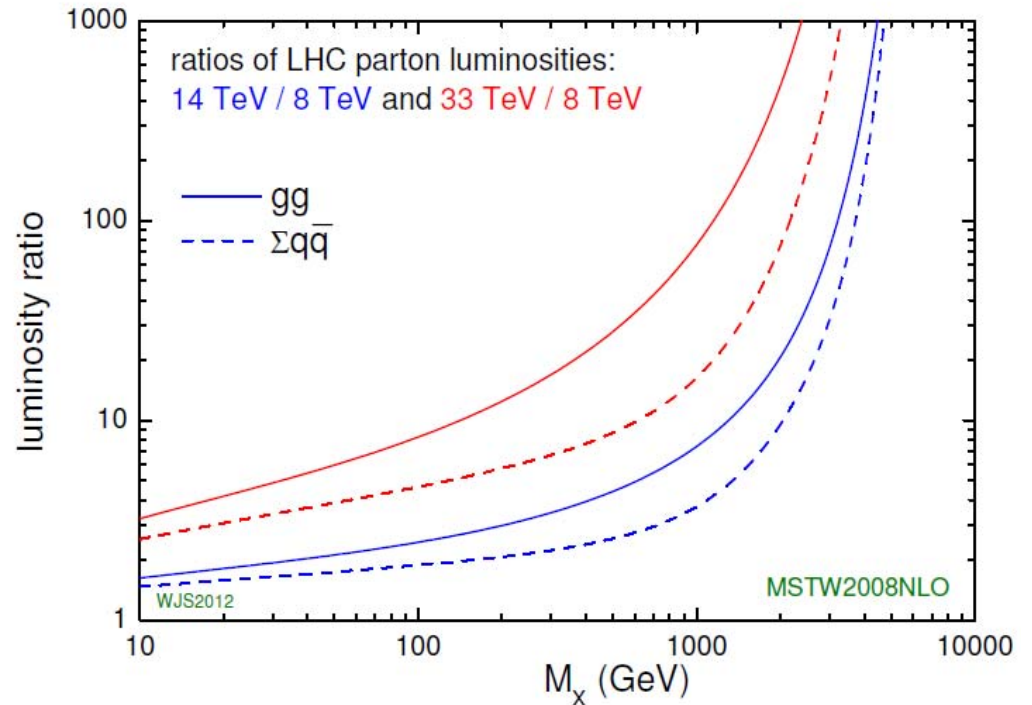

W J Stirling

LHC today

CMS EXOTICA 95% CL EXCLUSION LIMITS (TeV)

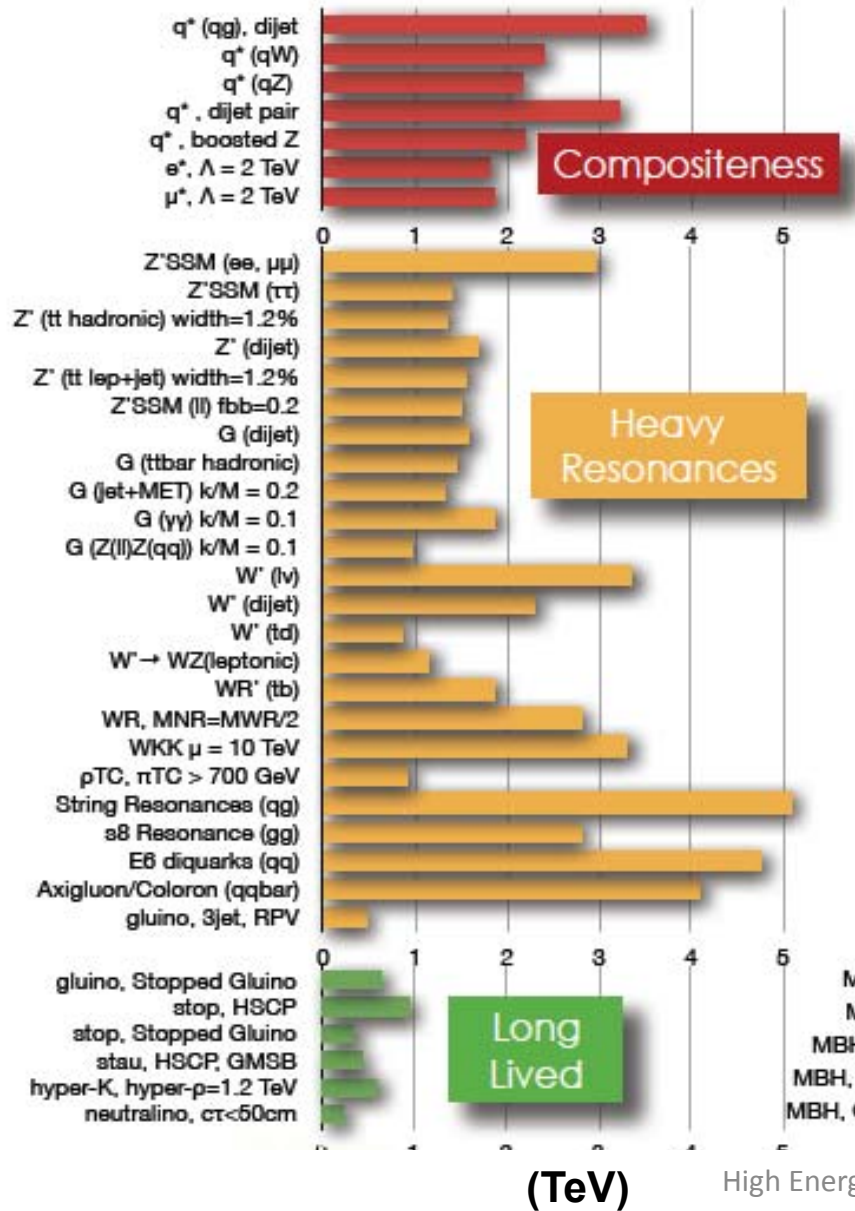

Similar results exist from ATLAS

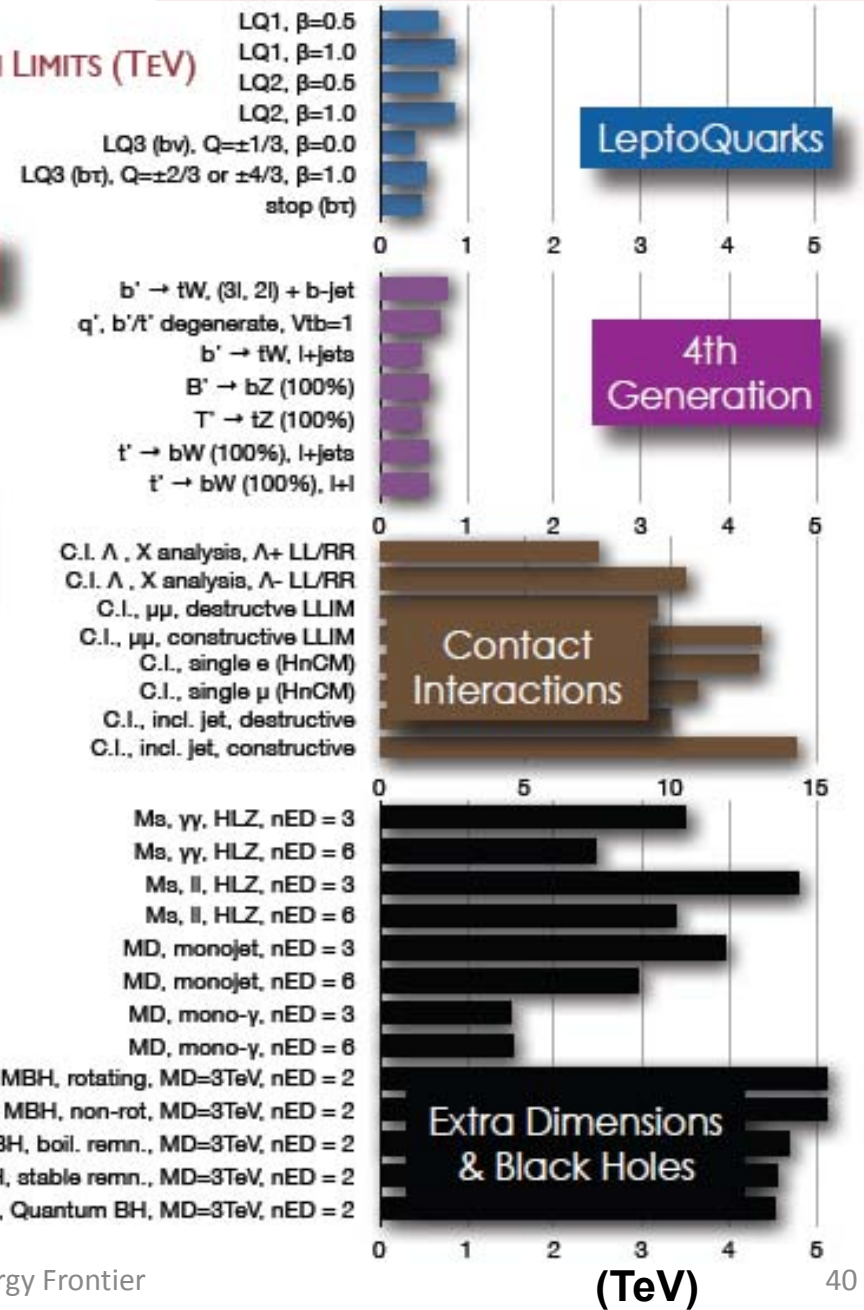

High Energy Frontier

ATLAS SUSY Searches* - 95% CL Lower Limits

Status: LHCP 2013

SUSY limits

ATLAS Preliminary

$$\int Ldt = (4.4 - 20.7) \text{ fb}^{-1} \quad \sqrt{s} = 7, 8 \text{ TeV}$$

Model	e, μ , τ , γ	Jets	E_T^{miss}	$\int Ldt$ [fb $^{-1}$]	Mass limit	Reference		
Inclusive searches	MSUGRA/CMSSM	0	2-6 jets	Yes	20.3	\tilde{q}, \tilde{g} 1.8 TeV	$m(\tilde{q})=m(\tilde{g})$	ATLAS-CONF-2013-047
	MSUGRA/CMSSM	1 e, μ	4 jets	Yes	5.8	\tilde{g}, \tilde{g} 1.24 TeV	$m(\tilde{q})=m(\tilde{g})$	ATLAS-CONF-2012-104
	MSUGRA/CMSSM	0	7-10 jets	Yes	20.3	\tilde{g}, \tilde{g} 1.1 TeV	any $m(\tilde{q})$	ATLAS-CONF-2013-054
	$\tilde{q}\tilde{q}, \tilde{g}\rightarrow q\tilde{\chi}_1^0$	0	2-6 jets	Yes	20.3	\tilde{q} 740 GeV	$m(\tilde{\chi}_1^0) = 0 \text{ GeV}$	ATLAS-CONF-2013-047
	$\tilde{g}\tilde{g}, \tilde{g}\rightarrow q\tilde{\chi}_1^0$	0	2-6 jets	Yes	20.3	\tilde{g} 1.3 TeV	$m(\tilde{\chi}_1^0) = 0 \text{ GeV}$	ATLAS-CONF-2013-047
	Giulino med. $\tilde{\chi}_1^{\pm}(\tilde{g}\rightarrow q\tilde{\chi}_1^{\pm})$	1 e, μ	2-4 jets	Yes	4.7	\tilde{g} 900 GeV	$m(\tilde{\chi}_1^{\pm}) < 200 \text{ GeV}, m(\tilde{\chi}_1^{\pm}) = 0.5(m(\tilde{\chi}_1^{\pm})+m(\tilde{g}))$	1208.4688
	$\tilde{g}\tilde{g}\rightarrow qq\tilde{q}l(l)\tilde{\chi}_1^0, \tilde{\chi}_1^0$	2 e, μ (SS)	3 jets	Yes	20.7	\tilde{g} 1.1 TeV	$m(\tilde{\chi}_1^{\pm}) < 650 \text{ GeV}$	ATLAS-CONF-2013-007
	GMSB (\perp NLSP)	2 e, μ	2-4 jets	Yes	4.7	\tilde{g} 1.24 TeV	$\tan\beta < 15$	1208.4688
	GMSB (\parallel NLSP)	1-2 τ	0-2 jets	Yes	20.7	\tilde{g} 1.4 TeV	$\tan\beta > 18$	ATLAS-CONF-2013-026
	GGM (bino NLSP)	2 γ	0	Yes	4.8	\tilde{g} 1.07 TeV	$m(\tilde{\chi}_1^0) > 50 \text{ GeV}$	1209.0753
	GGM (wino NLSP)	1 e, $\mu + \gamma$	0	Yes	4.8	\tilde{g} 619 GeV	$m(\tilde{\chi}_1^0) > 50 \text{ GeV}$	ATLAS-CONF-2012-144
	GGM (higgsino-bino NLSP)	γ	1 b	Yes	4.8	\tilde{g} 900 GeV	$m(\tilde{\chi}_1^0) > 220 \text{ GeV}$	1211.1167
	GGM (higgsino NLSP)	2 e, μ (Z)	0-3 jets	Yes	5.8	\tilde{g} 690 GeV	$m(\tilde{H}) > 200 \text{ GeV}$	ATLAS-CONF-2012-152
	Gravitino LSP	0	mono-jet	Yes	10.5	$F^{1/2}$ scale 645 GeV	$m(\tilde{G}) > 10^4 \text{ eV}$	ATLAS-CONF-2012-147
3 rd gen. \tilde{g} med.	$\tilde{g}\rightarrow b\tilde{\chi}_1^0$	0	3 b	Yes	12.8	\tilde{g} 1.24 TeV	$m(\tilde{\chi}_1^0) < 200 \text{ GeV}$	ATLAS-CONF-2012-145
	$\tilde{g}\rightarrow t\tilde{\chi}_1^0$	2 e, μ (SS)	0-3 b	No	20.7	\tilde{g} 900 GeV	$m(\tilde{\chi}_1^0) < 200 \text{ GeV}$	ATLAS-CONF-2013-007
	$\tilde{g}\rightarrow t\tilde{\chi}_1^0$	0	7-10 jets	Yes	20.3	\tilde{g} 1.14 TeV	$m(\tilde{\chi}_1^0) < 200 \text{ GeV}$	ATLAS-CONF-2013-054
	$\tilde{g}\rightarrow t\tilde{\chi}_1^0$	0	3 b	Yes	12.8	\tilde{g} 1.15 TeV	$m(\tilde{\chi}_1^0) < 200 \text{ GeV}$	ATLAS-CONF-2012-145
3 rd gen. squarks direct production	$\tilde{b}_1\tilde{b}_1, \tilde{b}_1\rightarrow b\tilde{\chi}_1^0$	0	2 b	Yes	20.1	\tilde{b}_1 100-630 GeV	$m(\tilde{\chi}_1^0) < 200 \text{ GeV}$	ATLAS-CONF-2013-053
	$\tilde{b}_1\tilde{b}_1, \tilde{b}_1\rightarrow \tilde{\chi}_1^0$	2 e, μ (SS)	0-3 b	Yes	20.7	\tilde{b}_1 430 GeV	$m(\tilde{\chi}_1^0) = 2m(\tilde{\chi}_1^0)$	ATLAS-CONF-2013-007
	$\tilde{t}_1\tilde{t}_1$ (light), $\tilde{t}_1\rightarrow b\tilde{\chi}_1^{\pm}$	1-2 e, μ	1-2 b	Yes	4.7	\tilde{t}_1 167 GeV	$m(\tilde{\chi}_1^0) = 55 \text{ GeV}$	1208.4305, 1209.2102
	$\tilde{t}_1\tilde{t}_1$ (light), $\tilde{t}_1\rightarrow Wb\tilde{\chi}_1^0$	2 e, μ	0-2 jets	Yes	20.3	\tilde{t}_1 220 GeV	$m(\tilde{\chi}_1^0) = m(\tilde{t}_1) - m(W) - 50 \text{ GeV}, m(\tilde{t}_1) < m(\tilde{\chi}_1^{\pm})$	ATLAS-CONF-2013-048
	$\tilde{t}_1\tilde{t}_1$ (medium), $\tilde{t}_1\rightarrow b\tilde{\chi}_1^{\pm}$	2 e, μ	0-2 jets	Yes	20.3	\tilde{t}_1 220 GeV	$m(\tilde{\chi}_1^0) = 0 \text{ GeV}, m(\tilde{t}_1) - m(\tilde{\chi}_1^{\pm}) = 10 \text{ GeV}$	ATLAS-CONF-2013-048
	$\tilde{t}_1\tilde{t}_1$ (medium), $\tilde{t}_1\rightarrow b\tilde{\chi}_1^0$	0	2 b	Yes	20.1	\tilde{t}_1 360 GeV	$m(\tilde{\chi}_1^0) < 200 \text{ GeV}, m(\tilde{\chi}_1^{\pm}) - m(\tilde{\chi}_1^0) = 5 \text{ GeV}$	ATLAS-CONF-2013-053
	$\tilde{t}_1\tilde{t}_1$ (heavy), $\tilde{t}_1\rightarrow t\tilde{\chi}_1^0$	1 e, μ	1 b	Yes	20.7	\tilde{t}_1 200-610 GeV	$m(\tilde{\chi}_1^0) = 0 \text{ GeV}$	ATLAS-CONF-2013-037
	$\tilde{t}_1\tilde{t}_1$ (heavy), $\tilde{t}_1\rightarrow t\tilde{\chi}_1^{\pm}$	0	2 b	Yes	20.1	\tilde{t}_1 320-660 GeV	$m(\tilde{\chi}_1^0) = 0 \text{ GeV}$	ATLAS-CONF-2013-024
	$\tilde{t}_1\tilde{t}_1$ (natural GMSB)	2 e, μ (Z)	1 b	Yes	20.7	\tilde{t}_1 500 GeV	$m(\tilde{\chi}_1^0) > 150 \text{ GeV}$	ATLAS-CONF-2013-025
	$\tilde{t}_2\tilde{t}_2, \tilde{t}_2\rightarrow \tilde{t}_1 + Z$	3 e, μ (Z)	1 b	Yes	20.7	\tilde{t}_2 520 GeV	$m(\tilde{t}_1) = m(\tilde{\chi}_1^0) + 180 \text{ GeV}$	ATLAS-CONF-2013-025
EW direct	$\tilde{L}_i\tilde{L}_i, \tilde{L}_i\rightarrow \tilde{\nu}_i$	2 e, μ	0	Yes	20.3	$\tilde{\chi}_1^{\pm}$ 85-315 GeV	$m(\tilde{\chi}_1^0) = 0 \text{ GeV}$	ATLAS-CONF-2013-049
	$\tilde{\chi}_1^{\pm}\tilde{\chi}_1^{\pm}, \tilde{\chi}_1^{\pm}\rightarrow \tilde{\nu}(\tilde{\nu})$	2 e, μ	0	Yes	20.3	$\tilde{\chi}_1^{\pm}$ 125-450 GeV	$m(\tilde{\chi}_1^0) = 0 \text{ GeV}, m(\tilde{\nu}) = 0.5(m(\tilde{\chi}_1^{\pm}) + m(\tilde{\chi}_1^0))$	ATLAS-CONF-2013-049
	$\tilde{\chi}_1^{\pm}\tilde{\chi}_1^{\pm}, \tilde{\chi}_1^{\pm}\rightarrow \tilde{\nu}(\tilde{\nu}) + \tau(\tilde{\nu})$	2 τ	0	Yes	20.7	$\tilde{\chi}_1^{\pm}$ 180-330 GeV	$m(\tilde{\chi}_1^0) = 0 \text{ GeV}, m(\tilde{\nu}) = 0.5(m(\tilde{\chi}_1^{\pm}) + m(\tilde{\chi}_1^0))$	ATLAS-CONF-2013-028
	$\tilde{\chi}_1^{\pm}\tilde{\chi}_2^0 \rightarrow \tilde{l}_i \nu \tilde{l}_i(\tilde{\nu} \nu), \tilde{\nu} \tilde{l}_i(\tilde{\nu} \nu)$	3 e, μ	0	Yes	20.7	$\tilde{\chi}_1^{\pm}, \tilde{\chi}_2^0$ 600 GeV	$m(\tilde{\chi}_1^{\pm}) = m(\tilde{\chi}_2^0), m(\tilde{\chi}_1^0) = 0, m(\tilde{\nu}) = 0.5(m(\tilde{\chi}_1^{\pm}) + m(\tilde{\chi}_1^0))$	ATLAS-CONF-2013-035
$\tilde{\chi}_1^{\pm}\tilde{\chi}_2^0 \rightarrow W^{\pm}\tilde{\chi}_1^0 Z^{\pm}\tilde{\chi}_1^0$	3 e, μ	0	Yes	20.7	$\tilde{\chi}_1^{\pm}, \tilde{\chi}_2^0$ 315 GeV	$m(\tilde{\chi}_1^0) = m(\tilde{\chi}_2^0), m(\tilde{\chi}_1^0) = 0, \text{ sleptons decoupled}$	ATLAS-CONF-2013-035	
Long-lived particles	Direct $\tilde{\chi}_1^{\pm}\tilde{\chi}_1^{\mp}$ prod., long-lived $\tilde{\chi}_1^{\pm}$	0	1 jet	Yes	4.7	$\tilde{\chi}_1^{\pm}$ 220 GeV	$1 < \tau(\tilde{\chi}_1^{\pm}) < 10 \text{ ns}$	1210.2852
	Stable g, R-hadrons	0-2 e, μ	0	Yes	4.7	\tilde{g} 985 GeV		1211.1597
	GMSB, stable $\tilde{\tau}, \text{ low } \beta$	2 e, μ	0	Yes	4.7	$\tilde{\tau}$ 300 GeV	$5 < \tan\beta < 20$	1211.1597
	GMSB, $\tilde{\chi}_1^0 \rightarrow \gamma G$, long-lived $\tilde{\chi}_1^0$	2 γ	0	Yes	4.7	$\tilde{\chi}_1^0$ 230 GeV	$0.4 < \tau(\tilde{\chi}_1^0) < 2 \text{ ns}$	1304.6310
	$\tilde{\chi}_1^0 \rightarrow qq\mu$ (RPV)	1 e, μ	0	Yes	4.4	\tilde{q} 700 GeV	$1 \text{ mm} < ct < 1 \text{ m}, \tilde{g} \text{ decoupled}$	1210.7451
RPV	LFV $pp \rightarrow \tilde{\nu}_e + X, \tilde{\nu}_e \rightarrow e + \mu$	2 e, μ	0	-	4.6	$\tilde{\nu}_e$ 1.61 TeV	$\lambda_{311} = 0.10, \lambda_{132} = 0.05$	1212.1272
	LFV $pp \rightarrow \tilde{\nu}_e + X, \tilde{\nu}_e \rightarrow e(\mu) + \tau$	1 e, $\mu + \tau$	0	-	4.6	$\tilde{\nu}_e$ 1.1 TeV	$\lambda_{311} = 0.10, \lambda_{1(2)33} = 0.05$	1212.1272
	Bilinear RPV CMSSM	1 e, μ	7 jets	Yes	4.7	\tilde{q}, \tilde{g} 1.2 TeV	$m(\tilde{q}) = m(\tilde{g}), c_{t, \text{LSP}} < 1 \text{ mm}$	ATLAS-CONF-2012-140
	$\tilde{\chi}_1^{\pm}\tilde{\chi}_1^{\mp}, \tilde{\chi}_1^0 \rightarrow e\tilde{\nu}_e, e\tilde{\nu}_e$	4 e, μ	0	Yes	20.7	$\tilde{\chi}_1^{\pm}, \tilde{\chi}_1^0$ 760 GeV	$m(\tilde{\chi}_1^0) > 300 \text{ GeV}, \lambda_{121} > 0$	ATLAS-CONF-2013-036
	$\tilde{\chi}_1^{\pm}\tilde{\chi}_1^{\mp}, \tilde{\chi}_1^0 \rightarrow \tau\tilde{\nu}_e, e\tilde{\nu}_e$	3 e, $\mu + \tau$	0	Yes	20.7	$\tilde{\chi}_1^{\pm}, \tilde{\chi}_1^0$ 350 GeV	$m(\tilde{\chi}_1^0) > 80 \text{ GeV}, \lambda_{133} > 0$	ATLAS-CONF-2013-036
	$\tilde{g} \rightarrow qq\tilde{q}$	0	6 jets	-	4.6	\tilde{g} 666 GeV		1210.4813
$\tilde{g} \rightarrow t\tilde{t}, \tilde{t}_1 \rightarrow bs$	2 e, μ (SS)	0-3 b	Yes	20.7	\tilde{g} 880 GeV		ATLAS-CONF-2013-007	
Other	Scalar gluon	0	4 jets	-	4.6	sgluon 100-287 GeV	incl. limit from 1110.2693	1210.4826
	WIMP interaction (D5, Dirac χ)	0	mono-jet	Yes	10.5	M^* scale 704 GeV	$m(\chi) < 80 \text{ GeV}, \text{ limit of } < 687 \text{ GeV for D8}$	ATLAS-CONF-2012-147

Very similar limits come from CMS

√s = 7 TeV full data
√s = 8 TeV partial data
√s = 8 TeV full data

High Energy Frontier

Mass scale [TeV]

*Only a selection of the available mass limits on new states or phenomena is shown. All limits quoted are observed minus 1 σ theoretical signal cross section uncertainty.

Beyond Standard Model reach for the HL-LHC

A factor 10 in luminosity gives further room for discoveries:

- Moderate gain in the searches of strongly coupled heavy objects. Typical improvement of about 20% in the mass reach.
- Substantial improvement in probing new states with smaller couplings than those assumed by sequential SM.
- Substantial improvement in probing new states beyond the kinematical reach of 14 TeV through precise measurement of the Higgs properties.

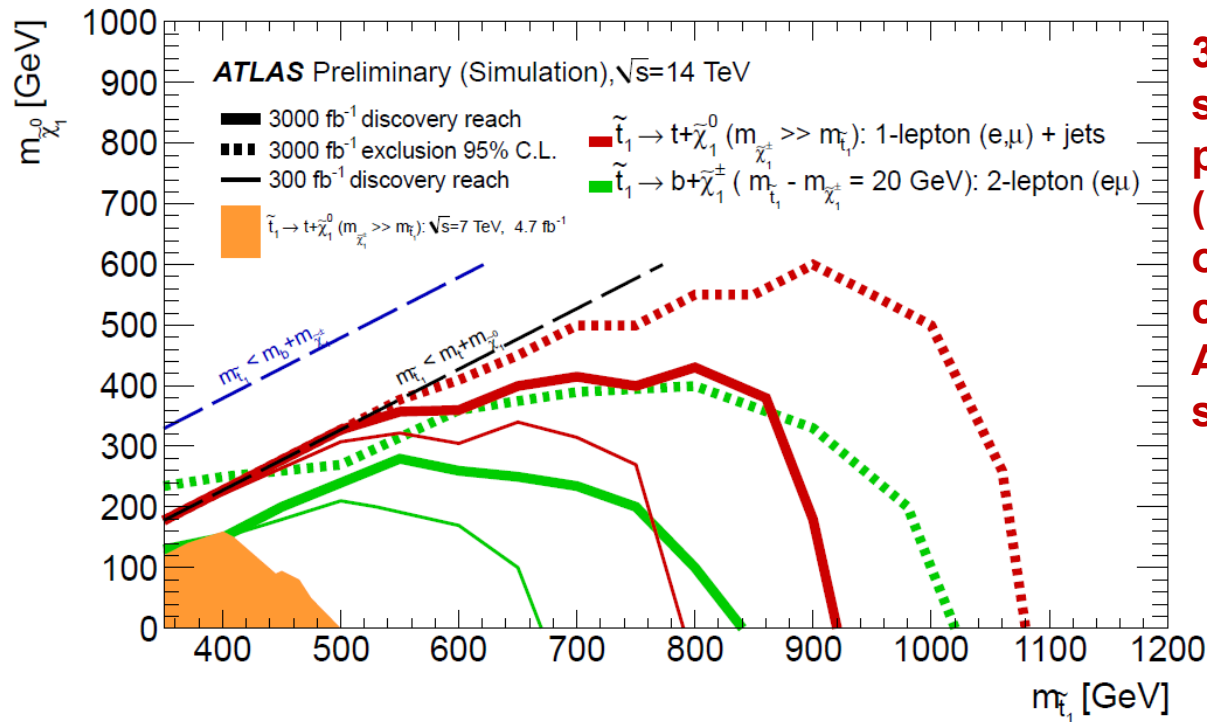

3^o generation squark have low x-sect: with 3000 fb^{-1} exclude the parameter space for a light stop (below 1 TeV) no matter the value of the LSP mass... A definitive challenge to SUSY & naturalness). And in case of discovery enough statistics for further studies...

From 'High Energy Frontier' presented by Marcella Diemoz at the ES Erice

Beyond Standard Model reach for the HL-LHC

A factor 10 in luminosity gives further room for discoveries:

- Moderate gain in the searches of strongly coupled heavy objects. Typical improvement of about 20% in the mass reach.
- Substantial improvement in probing new states with smaller couplings than those assumed by sequential SM.
- Substantial improvement in probing new states beyond the kinematical reach of 14 TeV through precise measurement of the Higgs properties.

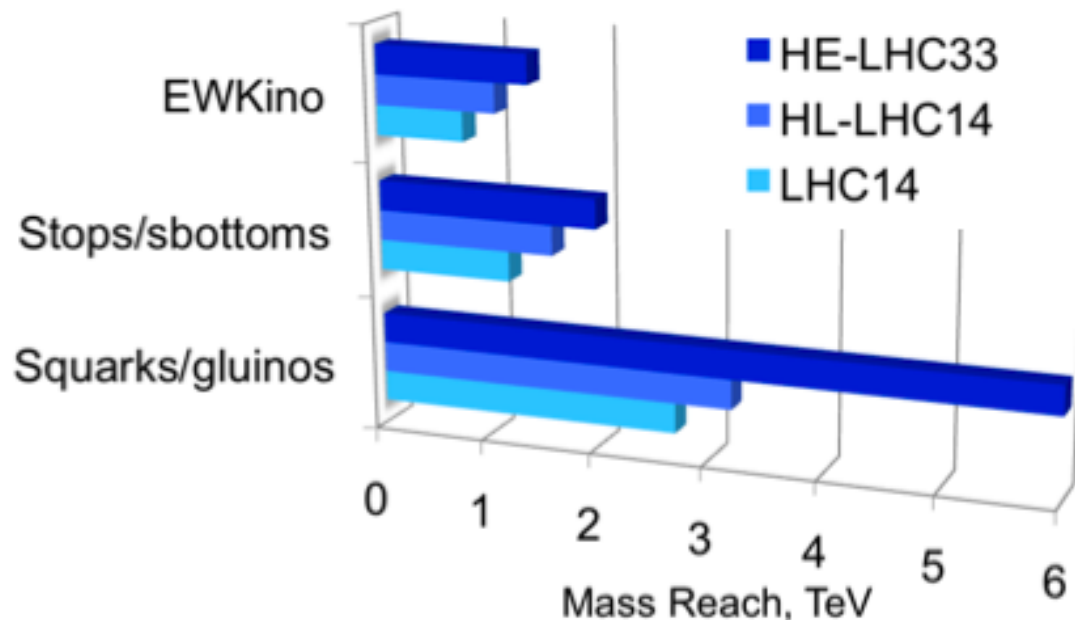

3^o generation squark have low σ -sect: with 3000 fb^{-1} exclude the parameter space for a light stop (below 1 TeV) no matter the value of the LSP mass... A definitive challenge to SUSY & naturalness). And in case of discovery enough statistics for further studies...

ES Open Symp. Contr. ID=141, 174

ES Open Symp. Contr. ID=144, 177

Standard Model physics examples for pp and $e+e-$

Examples from the HL-LHC Higgs studies of ATLAS and CMS

ES Open Symp. Contr. ID=141, 174

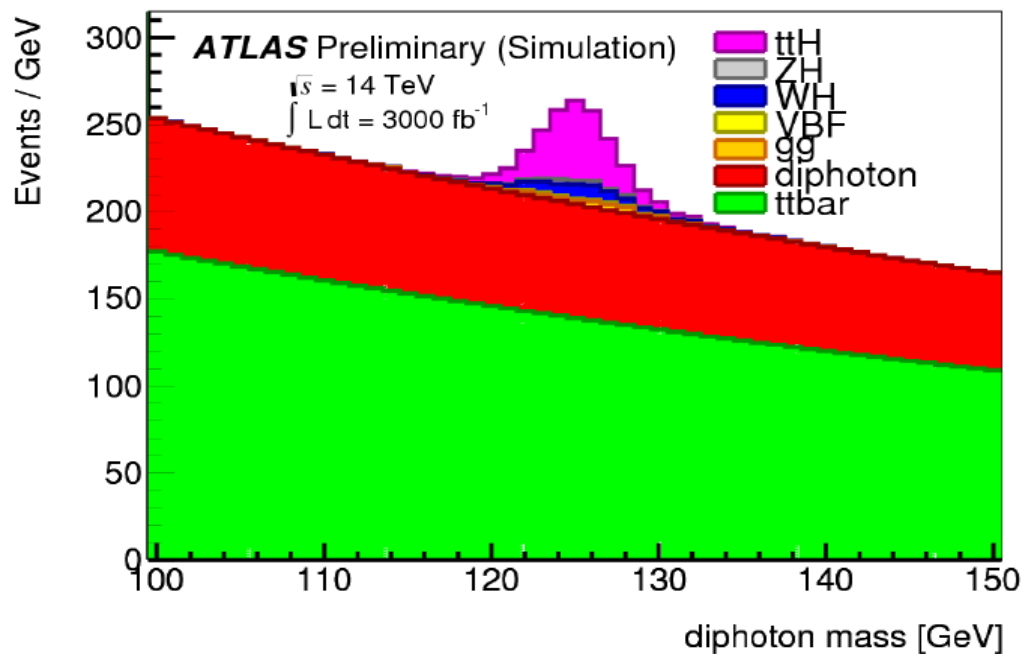

$ttH(\gamma\gamma)$

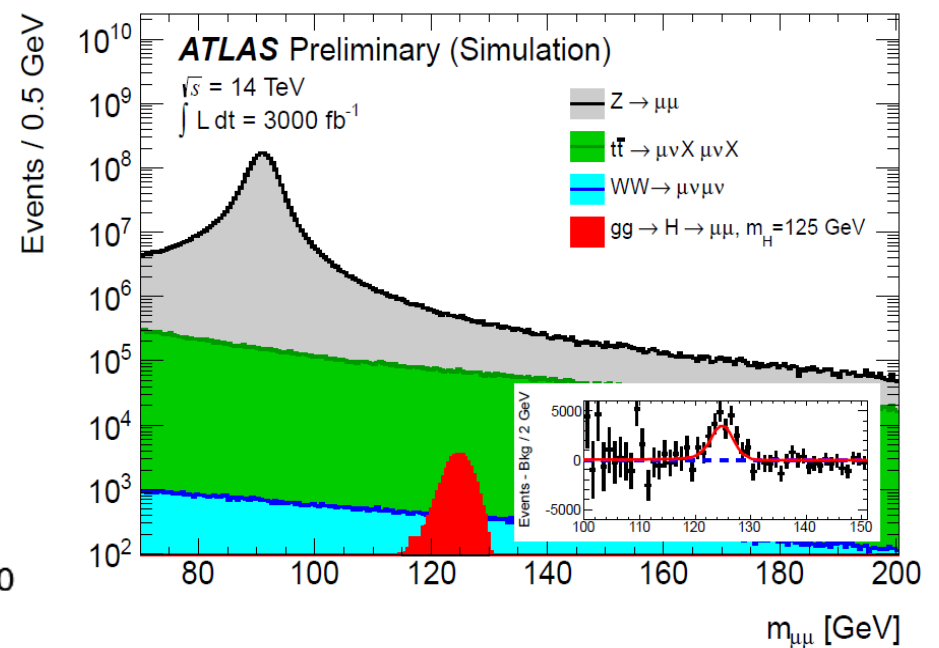

$H(\mu\mu)$

Access to rare production and decay processes

Profit from statistics:

- rare H production channels
- rare H decay channels
- H couplings
- Higgs self coupling (HH detection)
- VBS: dynamics of EWSB (is it SM?)
- New physics with suppressed couplings

CMS ESTIMATES

Coupling	300 fb^{-1}		3000 fb^{-1}	
	actual	scaled	actual	scaled
κ_γ	6.5	5.1	5.4	1.5
κ_V	5.7	2.7	4.5	1.0
κ_g	11	5.7	7.5	2.7
κ_b	15	6.9	11	2.7
κ_t	14	8.7	8.0	3.9
κ_T	8.5	5.1	5.4	2.0

ES Open Symp. Contr. ID=144, 177

ATLAS Preliminary (Simulation)

$\sqrt{s} = 14 \text{ TeV}$: $\int L dt = 300 \text{ fb}^{-1}$; $\int L dt = 3000 \text{ fb}^{-1}$

$\int L dt = 300 \text{ fb}^{-1}$ extrapolated from 7+8 TeV

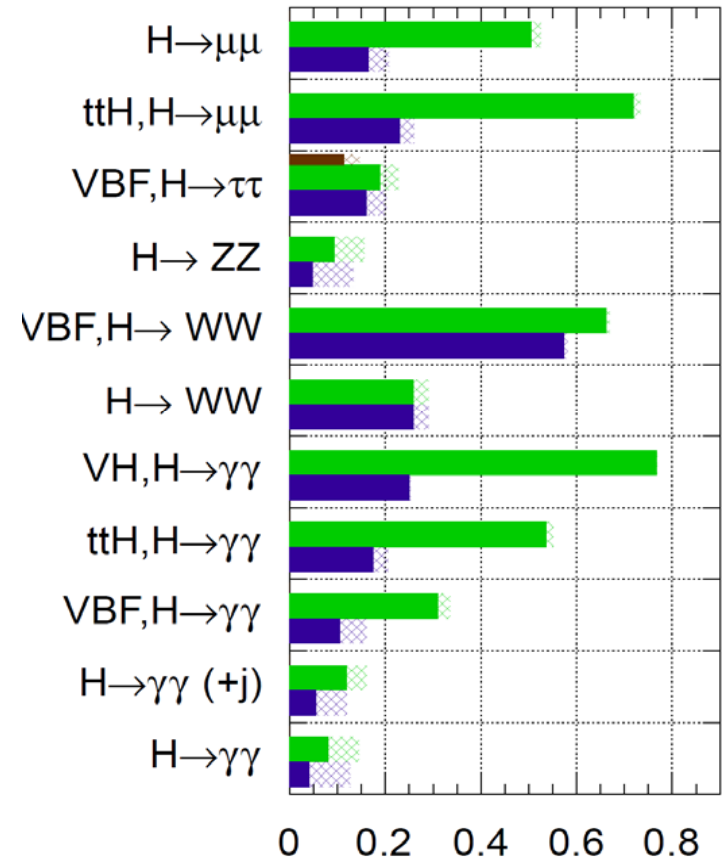

Precision on signal strengths $\frac{\Delta\mu}{\mu}$

High Energy Frontier

ES Open Symp. Contr. ID=141, 174

Precision Higgs measurements at e+e-

From 'High Energy Frontier' presented by Marcella Diemoz at the ES Erice

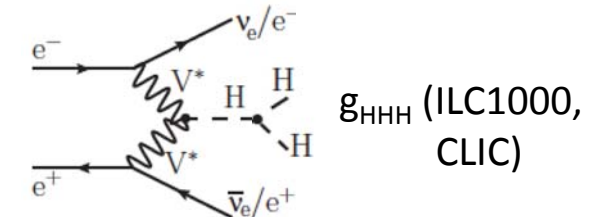
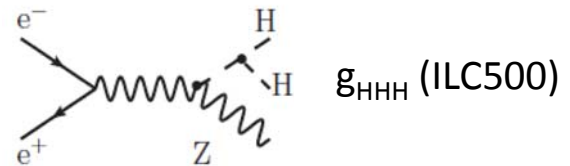
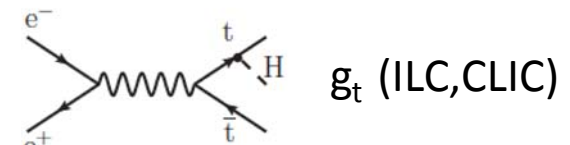
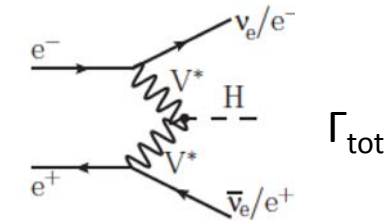
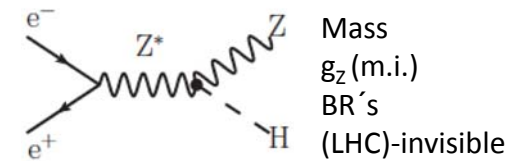
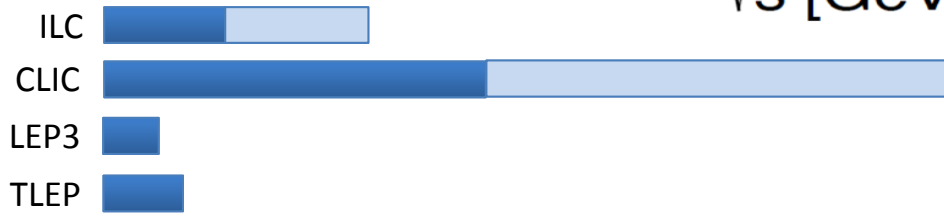
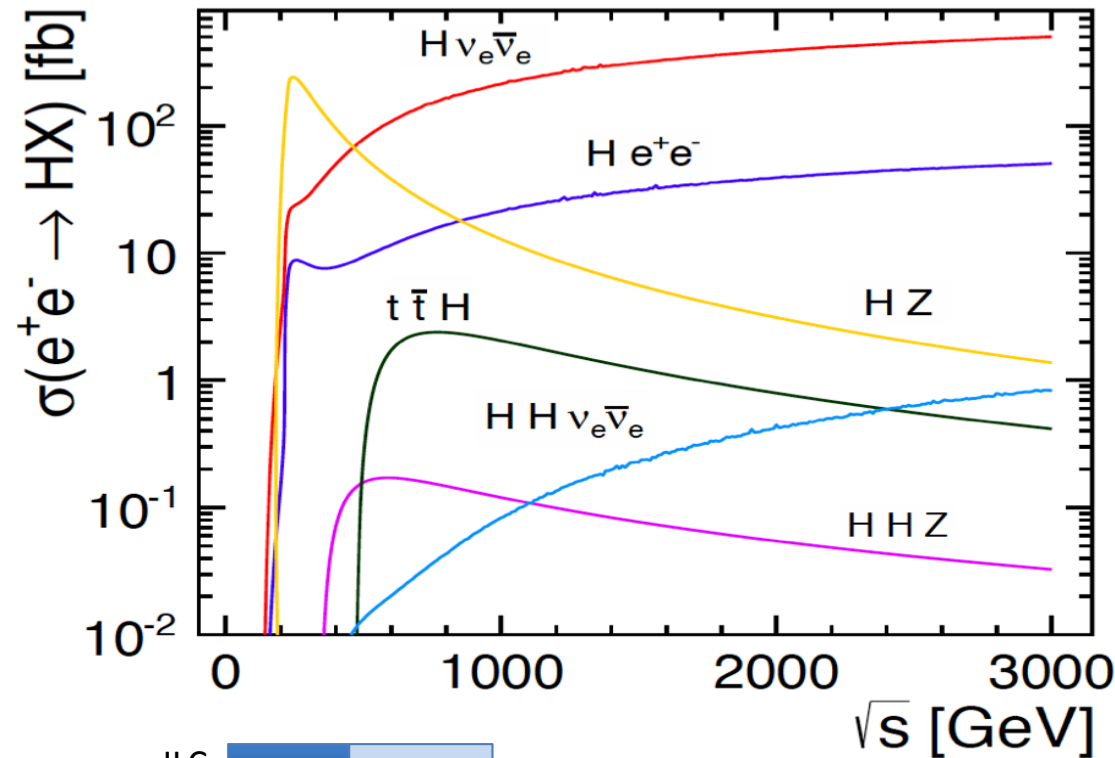

Many processes at different \sqrt{s} needed & accessible
HZ (at 250-350 GeV): recoil mass as anchor for model-independence

LC Higgs physics

ES Open Symp. Contr. ID=69

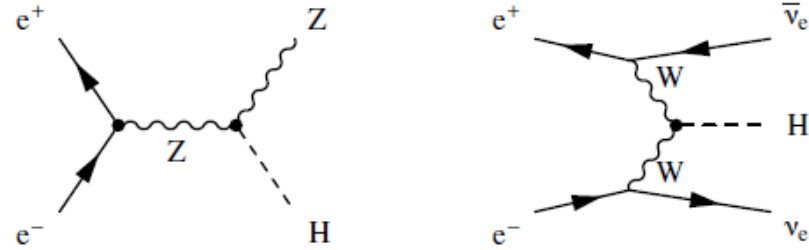

	250 GeV	350 GeV	500 GeV	1 TeV	1.5 TeV	3 TeV
$\sigma(e^+e^- \rightarrow ZH)$	240 fb	129 fb	57 fb	13 fb	6 fb	1 fb
$\sigma(e^+e^- \rightarrow H\nu_e\bar{\nu}_e)$	8 fb	30 fb	75 fb	210 fb	309 fb	484 fb
Int. \mathcal{L}	250 fb ⁻¹	350 fb ⁻¹	500 fb ⁻¹	1000 fb ⁻¹	1500 fb ⁻¹	2000 fb ⁻¹
# ZH events	60,000	45,500	28,500	13,000	7,500	2,000
# H $\nu_e\bar{\nu}_e$ events	2,000	10,500	37,500	210,000	460,000	970,000

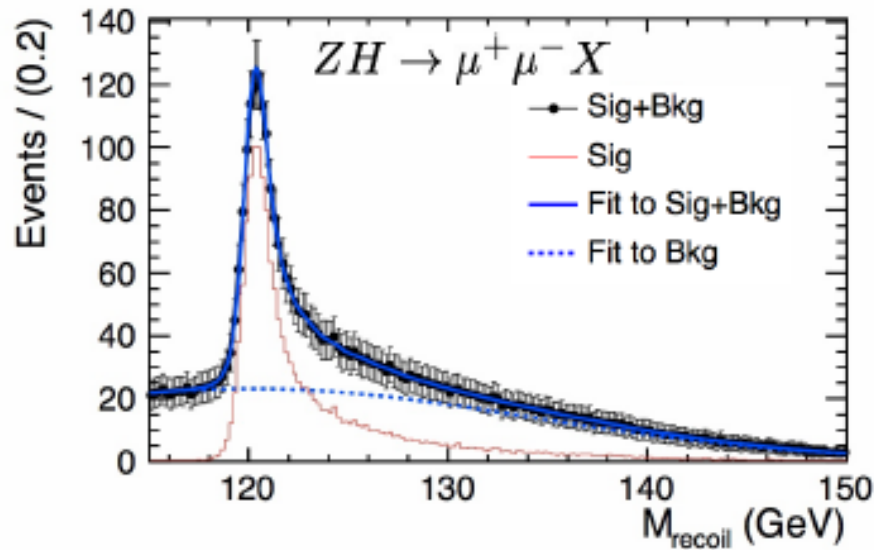

ILC/CLIC	250/350 GeV	500 GeV	3 TeV
g_{Hbb}	1.6/1.4%		2%
g_{Hcc}	4/3%	2%	2%
$g_{H\tau\tau}$	3/3%	2.5%	
g_{HWW}	4/3%	1.4%	<2%
$g_{H\mu\mu}$	–	–	7.5%
g_{HZZ}	1.5–2%		
g_{HWW}/g_{HZZ}			<1%
g_{ttH}	–	15%	
g_{HHH}	–	30–40%	20%
Γ_H	11/7%	5%	

Typical recoil mass distribution, for model-independent H studies

High Energy Frontier

250/350 fb⁻¹

500 fb⁻¹

1000 fb⁻¹

Global summary table (as compiled by TLEP)

ES Open Symp. Contr. ID=171, 173

	ILC	LEP3 (2)	LEP3 (4)	TLEP (2)	LHC (300)	HL-LHC
σ_{HZ}	3%	1.9%	1.3%	0.7%	–	–
$\sigma_{\text{HZ}} \times \text{BR}(\text{H} \rightarrow \text{bb})$	1%	0.8%	0.5%	0.2%	–	–
$\sigma_{\text{HZ}} \times \text{BR}(\text{H} \rightarrow \tau^+\tau^-)$	6%	3.0%	2.2%	1.3%	–	–
$\sigma_{\text{HZ}} \times \text{BR}(\text{H} \rightarrow \text{W}^+\text{W}^-)$	8%	3.6%	2.5%	1.6%	–	–
$\sigma_{\text{HZ}} \times \text{BR}(\text{H} \rightarrow \gamma\gamma)$?	9.5%	6.6%	4.2%	–	–
$\sigma_{\text{HZ}} \times \text{BR}(\text{H} \rightarrow \mu^+\mu^-)$	–	–	28%	17%	–	–
$\sigma_{\text{HZ}} \times \text{BR}(\text{H} \rightarrow \text{invisible})$?	1%	0.7%	0.4%	–	–
g_{HZZ}	1.5%	0.9%	0.6%	0.3%	13%/5.7%	4.5%
g_{Hbb}	1.6%	1.0%	0.7%	0.4%	21%/14.5%	11%
$g_{\text{H}\tau\tau}$	3%	2.0%	1.5%	0.6%	13%/8.5%	5.4%
g_{Hcc}	4%	?	?	0.9%	?/?	?
g_{HWW}	4%	2.2%	1.5%	0.9%	11%/5.7%	4.5%
$g_{\text{H}\gamma\gamma}$?	4.9%	3.4%	2.2%	?/6.5%	5.4%
$g_{\text{H}\mu\mu}$	–	–	14%	9%	?	?
g_{Htt}	–	–	–	–	14%	8%
$m_{\text{H}} (\text{MeV}/c^2)$	50	37	26	11	100	100

Notes

- LHC and e^+e^- measurements are not directly comparable
- ILC shown for 250/350 GeV, see previous slide for ILC/CLIC
- (2) and (4) for LEP3 and TLEP mean 2 or 4 experiments combined, assuming CMS performance enhanced with upgraded b and c tagging
- Current knowledge of theory systematics below 1% have been questioned

Tentative Higgs coupling summary (from the previous table)

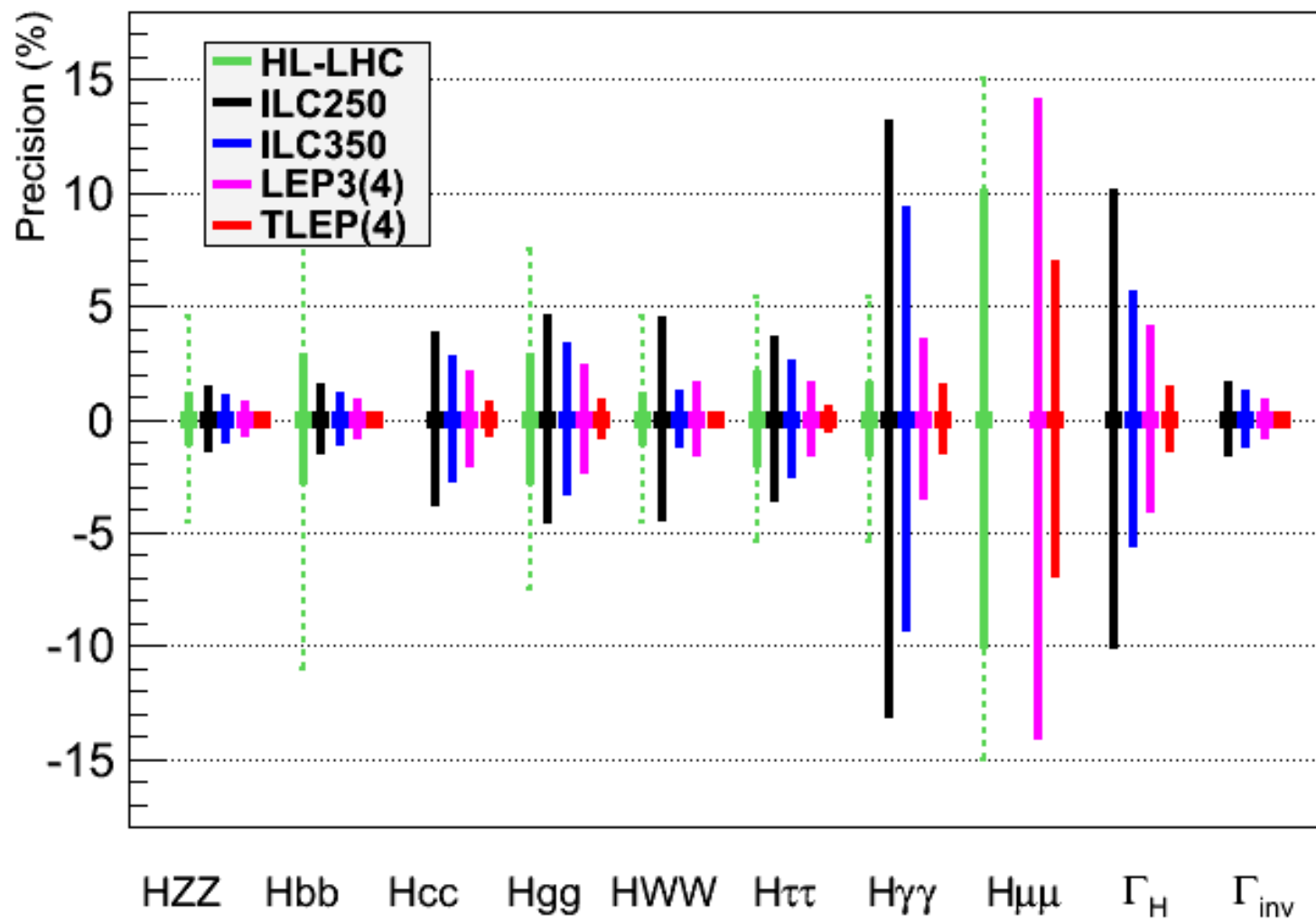

Looking even further ahead for Higgs couplings...

	$\sigma(14 \text{ TeV})$	R(33)	R(40)	R(60)	R(80)	R(100)
ggH	50.4 pb	3.5	4.6	7.8	11.2	14.7
VBF	4.40 pb	3.8	5.2	9.3	13.6	18.6
WH	1.63 pb	2.9	3.6	5.7	7.7	9.7
ZH	0.90 pb	3.3	4.2	6.8	9.6	12.5
ttH	0.62 pb	7.3	11	24	41	61
HH	33.8 fb	6.1	8.8	18	29	42

**Cross-section ratios
at pp colliders w.r.t.
the 14 TeV LHC**

ES Open Symp. Contr. ID=176

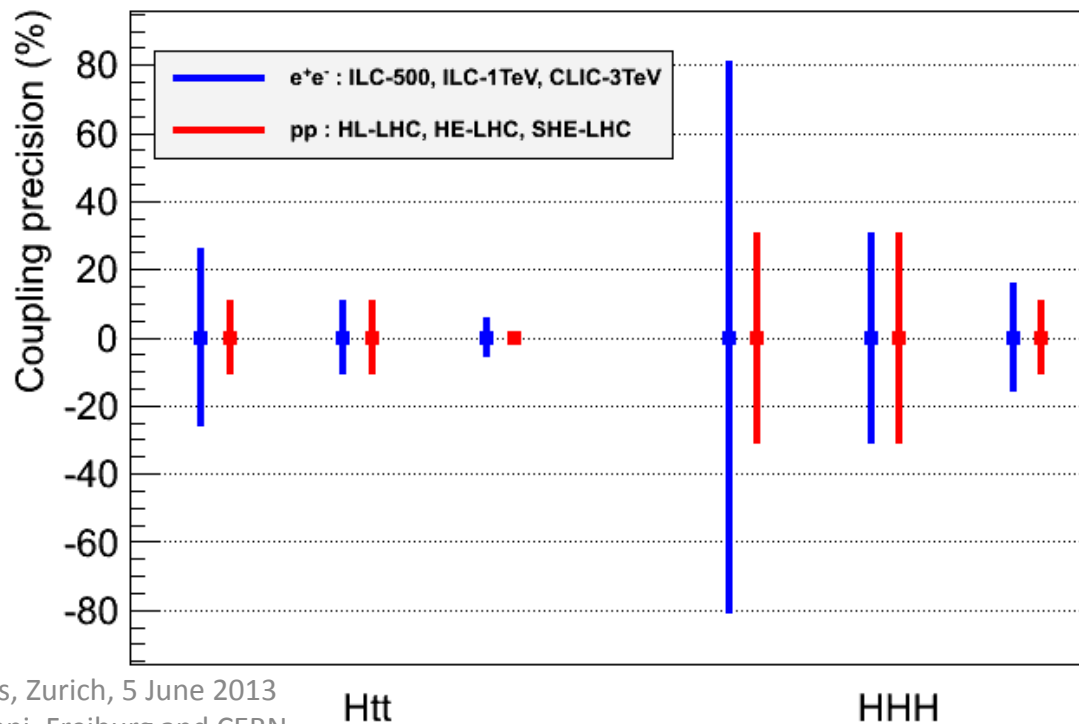

**Ultimate precisions for
Htt and HHH couplings
for three generations of
e⁺e⁻ (blue) and pp (red)
colliders**

P Janot, TLEP

There are many examples of e^+e^- precision measurements to test the consistency and stability of the Standard Model

Prime example is the top mass measurement

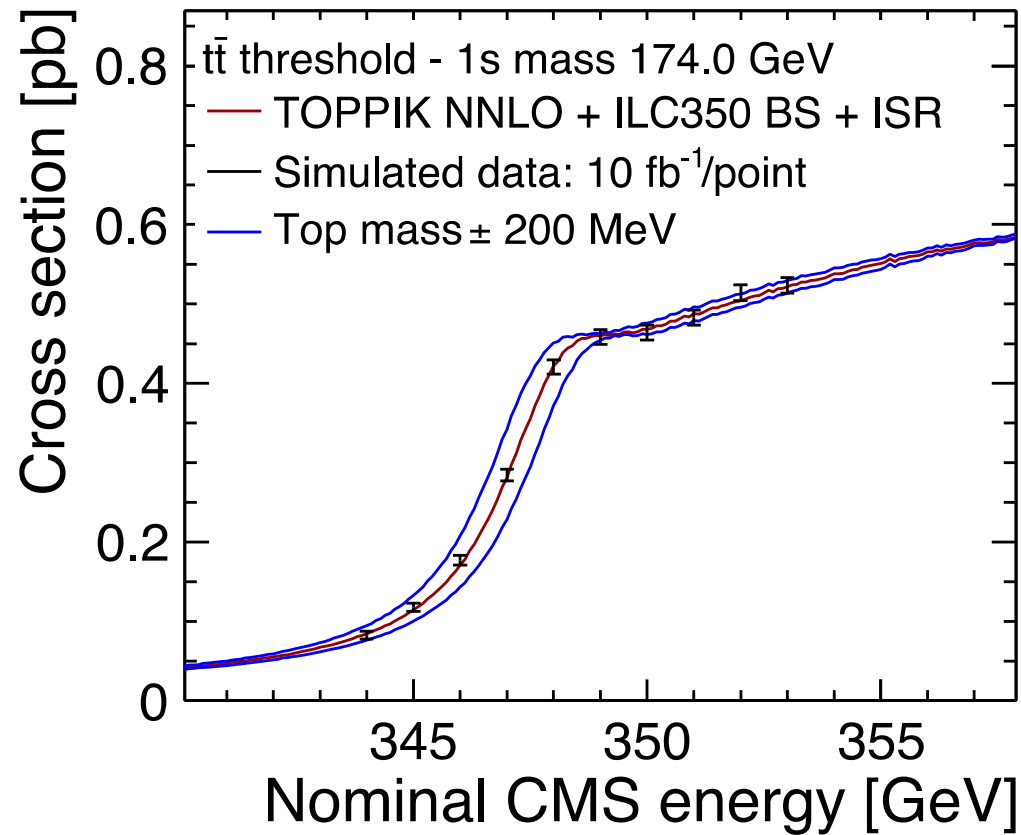

- $\Delta m_{\text{top}} = 20 \text{ MeV (stat.)}$
 100 MeV (theo.)
- $\Delta \Gamma_{\text{top}} = 30 \text{ MeV}$

ES Open Symp. Contr. ID=69

Test further the consistency of the SM w.r.t. the present situation

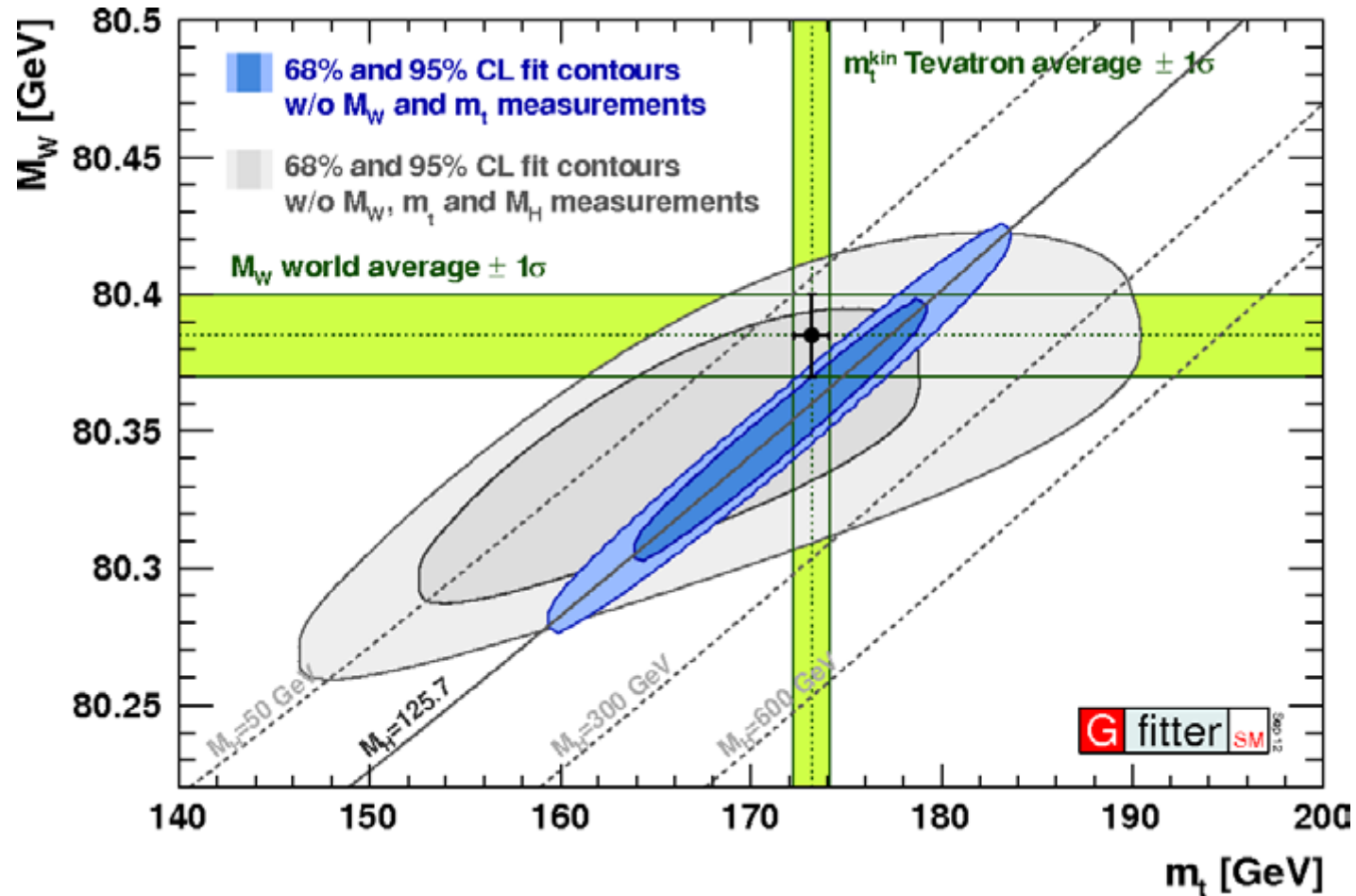

Gfitter group

Test further the vacuum stability of the SM w.r.t. the present situation

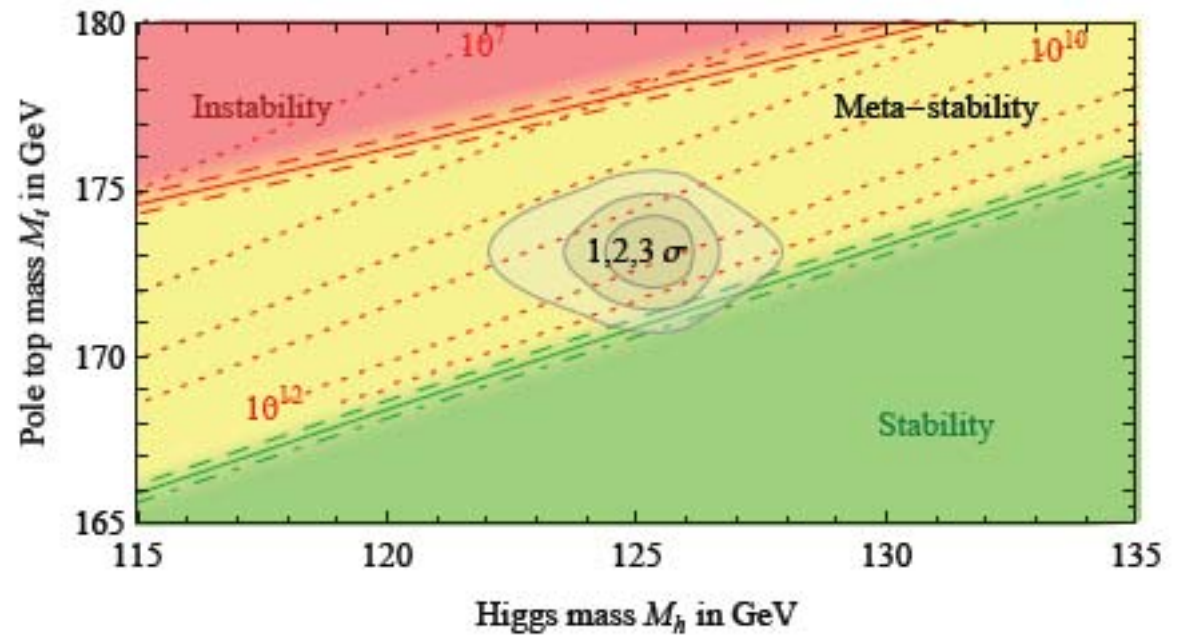
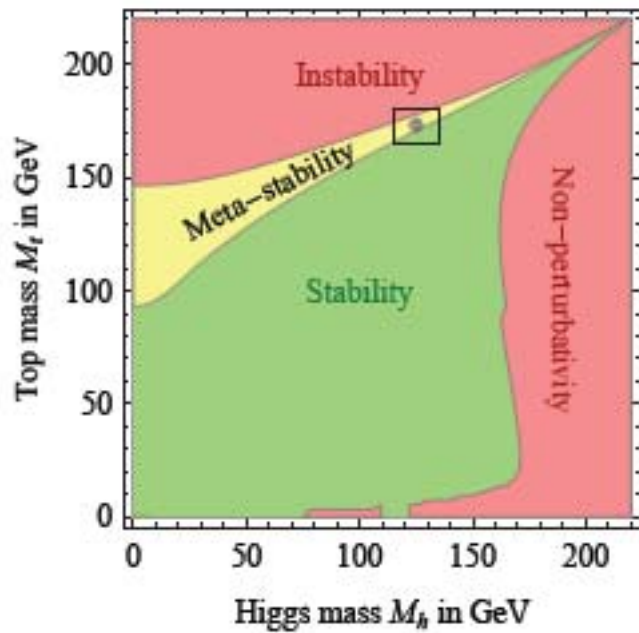

G Degrassi et al
arXiv: 1205.6497v1[hep-ph]

Update of the European Strategy for Particle Physics

(Worked out in draft form at Erice, 21 - 25 January 2013,
formally approved now on 30th May 2013 in Brussels)

The format of the document is such that the statements for each point are given in normal text, and then *the recommended actions in italics*

The points are labeled from a) to q)
such that they can be referred to easily;
it is **NOT** to be taken as an overall priority
ordering

*In what follows, only parts are reproduced,
and highlights in bold/colour are my own!*

Entrance to the former San Domenico
monastery with the Paul Dirac Lecture
Hall where the ES meeting took place



Erice ES meeting procedure

The content and the scientific arguments of all the 8 chapters of the Briefing Book were presented and discussed in detail on the first two days of the meeting

The third day was devoted to the presentation and discussion of the organizational and other matters covered by WG1 to WG5

The proposed strategy update was then elaborated during the last two days in an iterative process (*), arriving at a consensus

(*) The excellent steering and preparatory work of the Strategy Secretariat led by T Nakada with the SPC Chair F Zwirner, the ECFA Chair M Krammer and the representative of EU Lab Directors Ph. Chomaz deserves special mentioning!

Latsis, Zurich, 5 June 2013
P Jenni, Freiburg and CERN



High Energy Frontier

General issues

ESPP 2013 statement approved by Council

a) The success of the LHC is proof of the effectiveness of the European organisational model for particle physics, founded on the sustained long-term commitment of the CERN Member States and of the national institutes, laboratories and universities closely collaborating with CERN.

Europe should preserve this model in order to keep its leading role, sustaining the success of particle physics and the benefits it brings to the wider society.

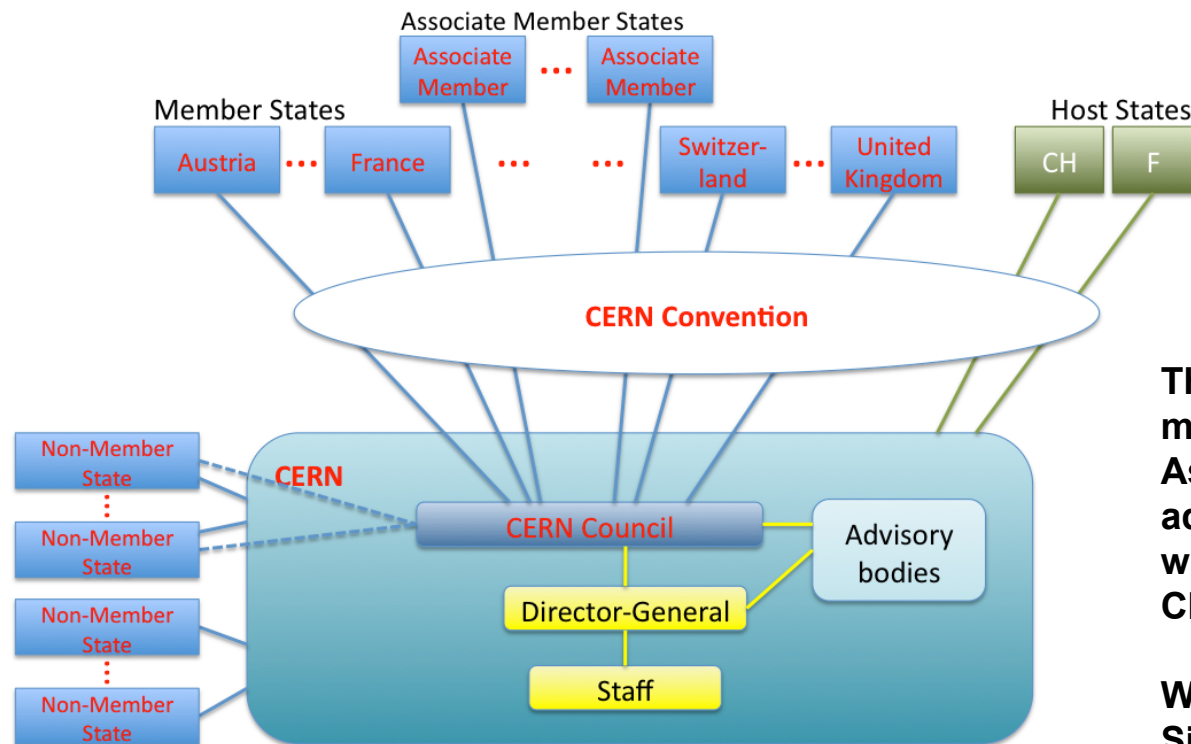

The current CERN governance model, including Member States, Associate Member States and ad-hoc partners with and without observer status in CERN Council

WG2 presentation by its convener Sijbrand de Jong

ESPP 2013 statement
approved by Council

b) The scale of the facilities required by particle physics is resulting in the globalisation of the field.

The European Strategy takes into account the worldwide particle physics landscape and developments in related fields and should continue to do so.

My personal
comments

This a very important statement for our field, and when it comes to concrete considerations it is by far not obvious how to implement in the best interest for the whole community

Europe can only act as a useful strong partner in a global context when it maintains CERN as focal point for its HEP community

High-priority large-scale scientific activities

After careful analysis of many possible large-scale scientific activities requiring significant resources, sizeable collaborations and sustained commitment, the following four activities have been identified as carrying the highest priority.

ESPP 2013 statement
approved by Council

c) The **discovery of the Higgs boson** is the start of a major programme of work to measure this particle's properties with the **highest possible precision for testing the validity of the Standard Model and to search for further new physics at the energy frontier**. The LHC is in a unique position to pursue this programme.

Europe's top priority should be the exploitation of the full potential of the LHC, including the high-luminosity upgrade of the machine and detectors with a view to collecting ten times more data than in the initial design, by around 2030. This upgrade programme will also provide further exciting opportunities for the study of flavour physics and the quark-gluon plasma.

My personal
comments

It could not be more explicit!

This 'result' was not given in advance, and the ATLAS and CMS inputs, as well as the ones from LHCb and ALICE, were very important for that (now 'we LHC people' have to continue to deliver though... !)

d) To stay at the forefront of particle physics, Europe needs to be in a position to propose an ambitious post-LHC accelerator project at CERN by the time of the next Strategy update, when physics results from the LHC running at 14 TeV will be available.

CERN should undertake design studies for accelerator projects in a global context, with emphasis on proton-proton and electron-positron high-energy frontier machines. These design studies should be coupled to a vigorous accelerator R&D programme, including high-field magnets and high-gradient accelerating structures, ***in collaboration with national institutes, laboratories and universities worldwide.***

This is to be understood as going clearly beyond ‘only’ technology R&D studies, by including all aspects of a future high energy frontier facility road map, and by keeping well in mind the ‘global context’

ESPP 2013 statement
approved by Council

e) **There is a strong scientific case for an electron-positron collider, complementary to the LHC, that can study the properties of the Higgs boson and other particles with unprecedented precision and **whose energy can be upgraded**. The Technical Design Report of the International Linear Collider (ILC) has been completed, with large European participation. **The initiative from the Japanese particle physics community to host the ILC in Japan is most welcome, and European groups are eager to participate.****

Europe looks forward to a proposal from Japan to discuss a possible participation.

Council can only discuss the needed resources and implications of a participation in a global ILC project in Japan when an official proposal is on the table, but there is no doubt that there is considerable interest for it in the European community

My personal
comments

However, the future of CERN must remain secured, as said before, while contributing to healthy physics activities in other regions

Latsis, Zurich, 5 June 2013
P Jenni, Freiburg and CERN

**Via San Francesco,
the only long straight
street in Erice**



ESPP 2013 statement
approved by Council

f) Rapid progress in neutrino oscillation physics, with significant European involvement, has established a **strong scientific case for a long-baseline neutrino programme exploring CP violation and the mass hierarchy** in the neutrino sector.

*CERN should develop a neutrino programme to pave the way for a **substantial European role in future long-baseline experiments. Europe should explore the possibility of major participation in leading long-baseline neutrino projects in the US and Japan.***

My personal
comments

I think the message is clear, I have no further comment...



**The Norman Castle and
the Castello Pepoli Erice**

All the next sections are very important as well, but regrettably there is no time to report in full on them here (only the headings, and some selected parts are shown, please read the full draft text!)

Other scientific activities essential to the particle physics programme

g) **Theory is a strong driver of particle physics**

h) Experiments studying quark flavour physics, investigating dipole moments, searching for charged lepton flavour violation and performing other precision measurements at lower energies ... **may give access to higher energy scales ...**
They can be based in national laboratories...

Experiments in Europe with unique reach should be supported, as well as participation in experiments in other regions of the world.

i) The success of particle physics experiments, such as those required for the high-luminosity LHC, relies on **innovative instrumentation, state-of-the-art infrastructures and large-scale data-intensive computing...**

j) A range of important non-accelerator experiments take place at **the overlap of particle and astroparticle physics...** (close collaboration with ApPEC)

k) A variety of **research lines at the boundary between particle and nuclear physics** require dedicated experiments. ... *CERN should continue to work with NuPECC on topics of mutual interest.*

Organisational issues

ESPP 2013 statement
approved by Council

l) Future major facilities in Europe and elsewhere require collaboration on a global scale.

CERN should be the framework within which to organise a global particle physics accelerator project in Europe, and should also be the leading European partner in global particle physics accelerator projects elsewhere. Possible additional contributions to such projects from CERN's Member and Associate Member States in Europe should be coordinated with CERN.

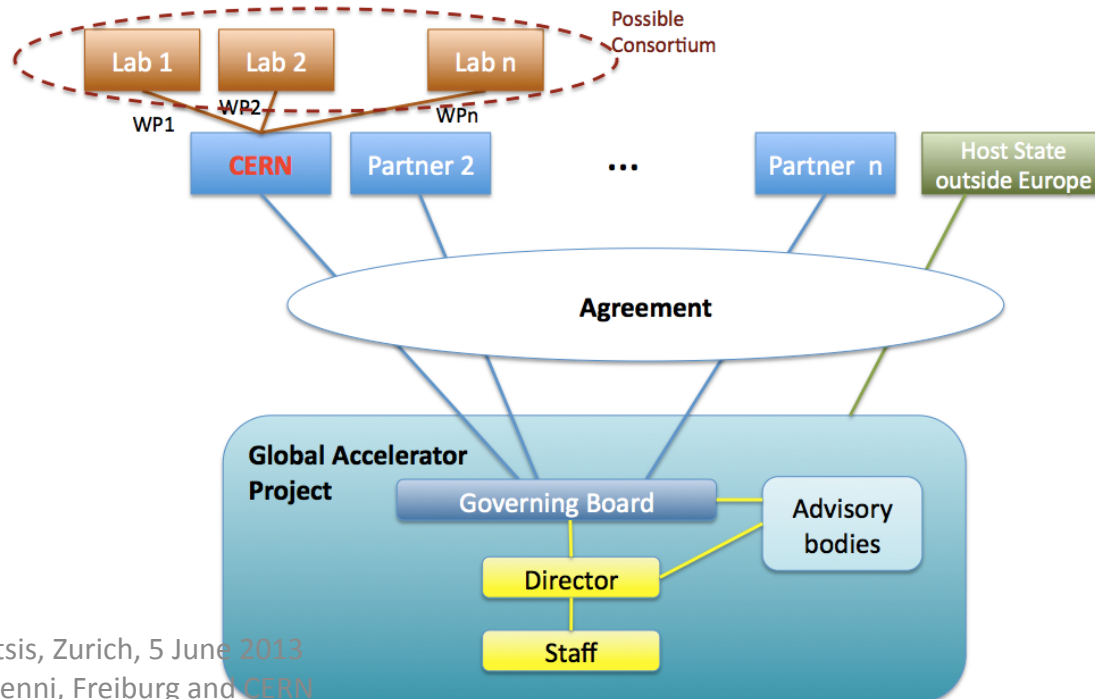

Example of possible participation of European national laboratories through CERN in global projects outside Europe

WG2 presentation by its convener Sijbrand de Jong

m) A Memorandum of Understanding has been signed by CERN and the European Commission, and various cooperative activities are under way...

... CERN and the particle physics community should strengthen their relations with the European Commission ...

Wider impact of particle physics

n) Sharing the excitement of scientific discoveries with the public ...
is part of our duty as researchers.....

o) Knowledge and technology developed for particle physics research...

p) Particle physics research requires a wide range of skills and knowledge...

Concluding recommendations

ESPP 2013 statement
approved by Council

q) **This is the first update of the European Strategy for Particle Physics.** It was prepared by the European Strategy Group based on the scientific input from the Preparatory Group with the participation of representatives of the Candidate for Accession to Membership, the Associate Member States, the Observer States and of other organisations. **Such periodic updates at intervals of about five years are essential.**

Updates should continue to be undertaken according to the principles applied on the present occasion. The organisational framework for the Council Sessions dealing with European Strategy matters and the mechanism for implementation and follow-up of the Strategy should be revisited in the light of the experience gained since 2006.

My personal
comments

We arrived at point q), that's it...

Latsis, Zurich, 5 June 2013
P Jenni, Freiburg and CERN

One of the many nice restaurants and bars in Erice, but closed in January...



Some history: 26 years ago ...

La Thuile 7 – 13 January 1987

(Carlo Rubbia's Long Range Planning Committee)

Collider parameters

Machine	\sqrt{s} (TeV)	L ($\text{cm}^{-2} \text{s}^{-1}$)
LHC	pp	$10^{33} \rightarrow 10^{34}$
	ep	1.3
1.8		10^{31}
CLIC	e^+e^-	$10^{33} \rightarrow 10^{34}$

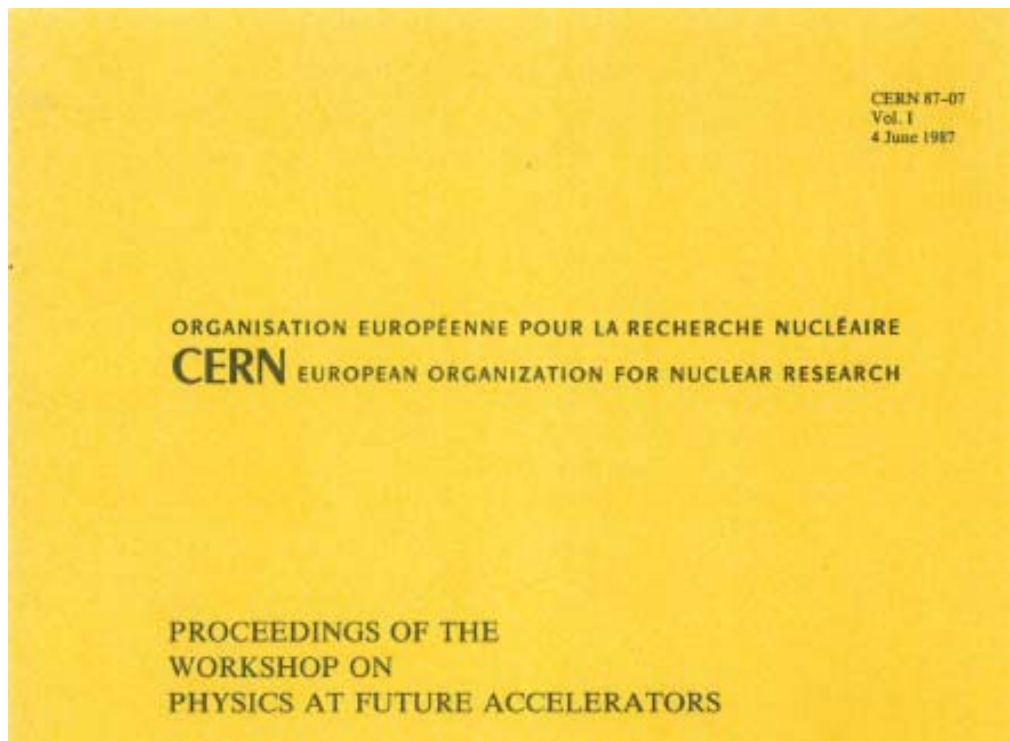

La Thuile (Italy) and Geneva (Switzerland)
7 – 13 January 1987

Vol. I

Latsis, Zurich, 5 June 2013
P Jenni, Freiburg and CERN

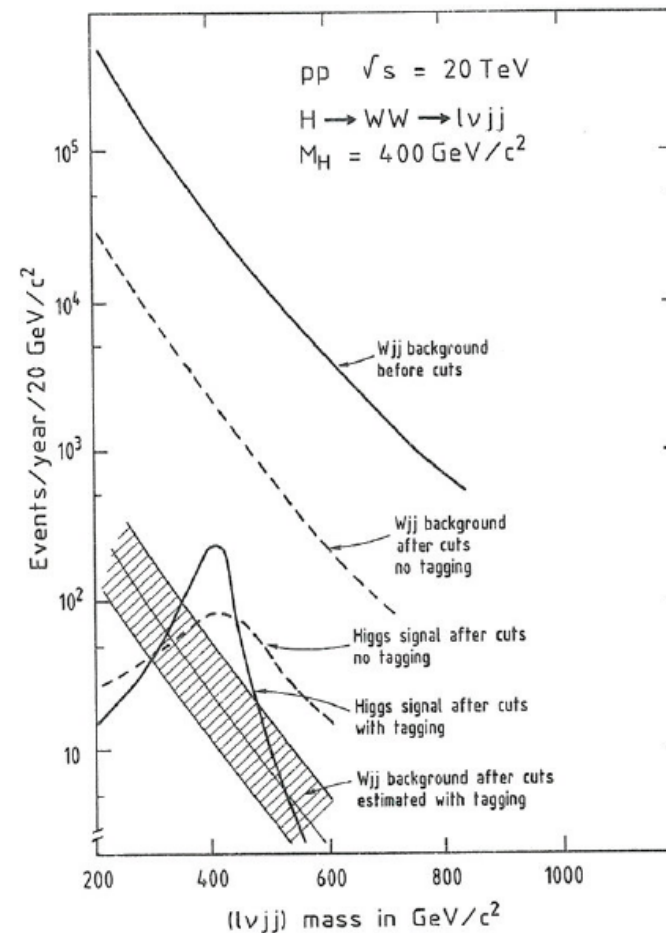
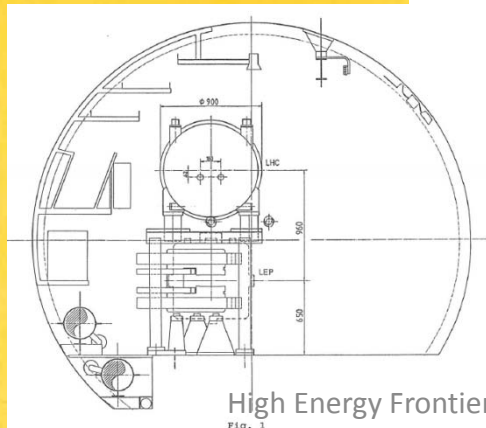

Time line of the LHC project

1984	Workshop on a Large Hadron Collider in the LEP tunnel, Lausanne.
1987	Workshop on Physics at Future Accelerators, La Thuile, Italy. The Rubbia “Long-Range Planning Committee” recommends the Large Hadron Collider as the right choice for CERN’s future.
1990	European Committee for Future Accelerators (ECFA) LHC Workshop, Aachen (discussion of physics, technologies and designs for LHC experiments)
1992	General Meeting on LHC Physics and Detectors, Evian les Bains (4 general-purpose experiment designs presented along with their physics performance)
1993	Three Letters of Intent submitted to the CERN peer review committee LHCC. ATLAS and CMS selected to proceed to a detailed technical proposal.
1994	The LHC accelerator approved for construction
1996	ATLAS and CMS Technical Proposals approved.
1997	Formal approval for ATLAS and CMS to move to construction (materials cost ceiling of 475 MCHF)
1997	Construction commences (after approval of detailed engineering design of subdetectors (magnets, inner tracker, calorimeters, muon system, trigger and data acquisition))
2000	Assembly of experiments commences, LEP accelerator is closed down to make way for the LHC.
2008	LHC experiments ready for pp collisions. LHC starts operation. An incident stops LHC operation.
2009	LHC restarts operation, pp collisions recorded by LHC detectors
2010	LHC collides protons at high energy (centre of mass energy of 7 TeV)
2012	LHC operates at 8 TeV: discovery of a Higgs-like boson.

It took a long time, and we already had a tunnel...

Another example where we have to be even more patient...

SLAC – PUB – 4081
 September 1986
 (A/E)

Table I. Parameters of some 10 TeV (c.m.) linear colliders compared to the parameters of the SLC. The c.m. energy spread, σ_{E^*}/E^* , is the contribution of beamstrahlung only.

MACHINE	L.L.C.			SLC
E^* (TeV)	10			0.1
\mathcal{L} ($\text{cm}^{-2}\text{s}^{-1}$)	10^{34}			6×10^{30}
σ_{E^*}/E^* (%)	10			0.04
β^* (cm)	0.1			0.5
D	0.1			1.0
P (MW)	1	3	10	0.16
f (Hz)	3000	9000	30,000	180
N (e^+ or e^-)	4.1×10^8	4.1×10^8	4.1×10^8	5×10^{10}
ϵ_N (M)	4×10^{-9}	1.2×10^{-8}	4×10^{-8}	3×10^{-5}
σ_{r_0} (micron)	6.4×10^{-4}	1.1×10^{-3}	2×10^{-3}	1.5
σ_x (mm)	3.4×10^{-4}	1×10^{-3}	3.4×10^{-3}	1.5

...

that will occur. I do not believe that the next step in linear colliders beyond the SLC will be the 10 TeV machine described in my Table. That is too big a distance from the parameters of the SLC to be covered in a single step. Thus we will have to see a machine of $1 \pm 1/2$ TeV as a “intermediate” machine. It is “intermediate” only when compared to the machine of Table I — it will be a very exciting research tool in its own right. Our

...

Burt Richter

The journey into new physics territory at the high-energy frontier has only just begun with the LHC, and for sure, exciting times will be ahead of us!



But we need to make timely plans and courageous decisions on a global scale in order to 'plant the right seeds for the future', also beyond LHC

Thank you for your attention

Backup

The SM is not a complete theory

Some of the outstanding questions in fundamental physics addressed, at least in part, with the LHC are:

What is the origin of the elementary particle masses ?

(~✓)

What is the nature of the Universe dark matter ?

Why is only matter observed in the Universe as primary constituents and not anti-matter ?

What are the features of the primary particles produced at present $\sim 10 \mu\text{s}$ after the Big Bang ?

What is the nature of the forces in the Universe ?

Are there additional forces in addition to the known four ?

Are there additional (microscopic) space dimensions ?

.....

New Physics beyond the Standard Model is needed to answer these and other questions. The huge amount of precise experimental data collected so far indicate that this New Physics could manifest itself at the $\sim \text{TeV}$ energy scale being explored by the LHC

CERN Press Release 30th May 2013:

Key points of the strategy are that Europe, and the European particle physics community, should:

Exploit its current world-leading facility for particle physics, the LHC, to its full potential over a period of many years, with a series of planned upgrades;

Continue to develop novel techniques leading to ambitious future accelerator projects on a global scale;

Be open to engagement in a range of unique basic physics research projects alongside the LHC;

Be open to collaboration in particle physics projects beyond the European region;

Maintain a healthy base in fundamental physics research, with universities and national laboratories contributing to a strong European focus through CERN;

Continue to invest substantial effort in communication, education and outreach to engage global publics with science.

	nominal LHC	HE-LHC
beam energy [TeV]	7	16.5
dipole field [T]	8.33	20
dipole coil aperture [mm]	56	40-45
#bunches / beam	2808	1404
bunch population [10^{11}]	1.15	1.29
initial transverse normalized emittance [μm]	3.75	3.75 (x), 1.84 (y)
number of IPs contributing to tune shift	3	2
maximum total beam-beam tune shift	0.01	0.01
IP beta function [m]	0.55	1.0 (x), 0.43 (y)
full crossing angle [μrad]	285 ($9.5 \sigma_{x,y}$)	175 ($12 \sigma_{x0}$)
stored beam energy [MJ]	362	479
SR power per ring [kW]	3.6	62.3
longitudinal SR emittance damping time [h]	12.9	0.98
events per crossing	19	76
peak luminosity [$10^{34} \text{ cm}^{-2}\text{s}^{-1}$]	1.0	2.0
beam lifetime [h]	46	13
integrated luminosity over 10 h [fb^{-1}]	0.3	0.5

proton - (anti)proton cross sections

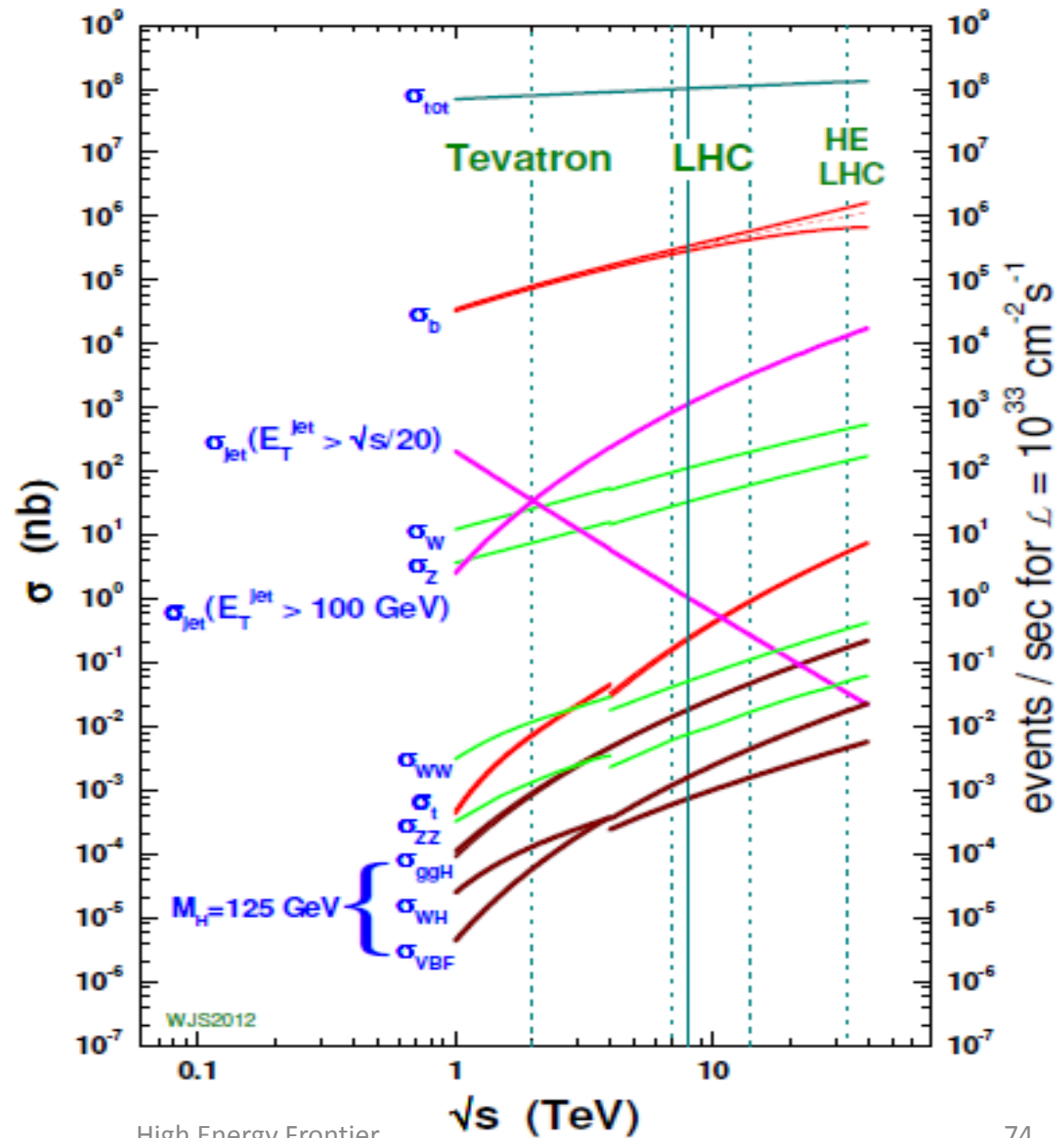

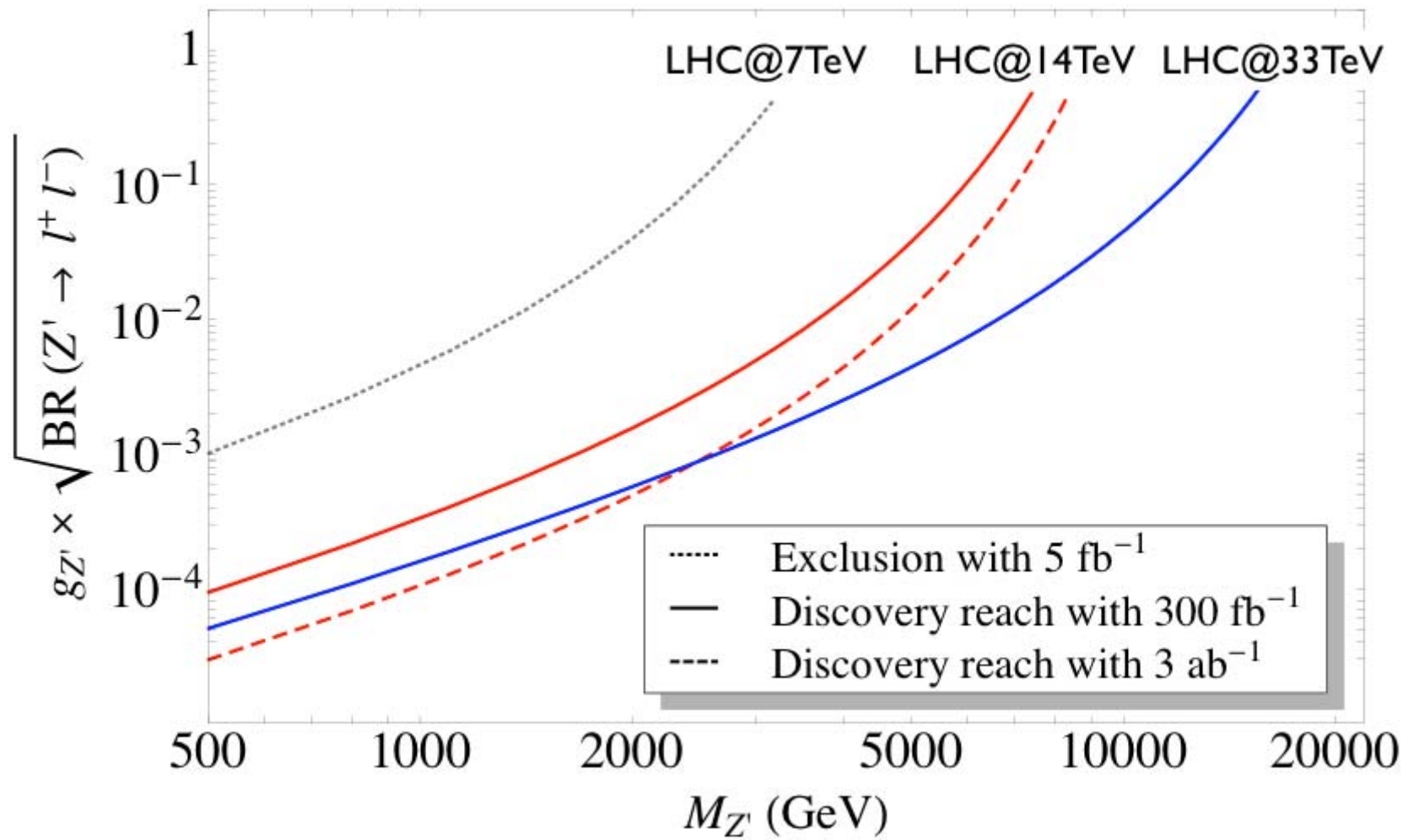

The super-exploitation of the CERN complex: Injectors, LEP/LHC tunnel, infrastructures

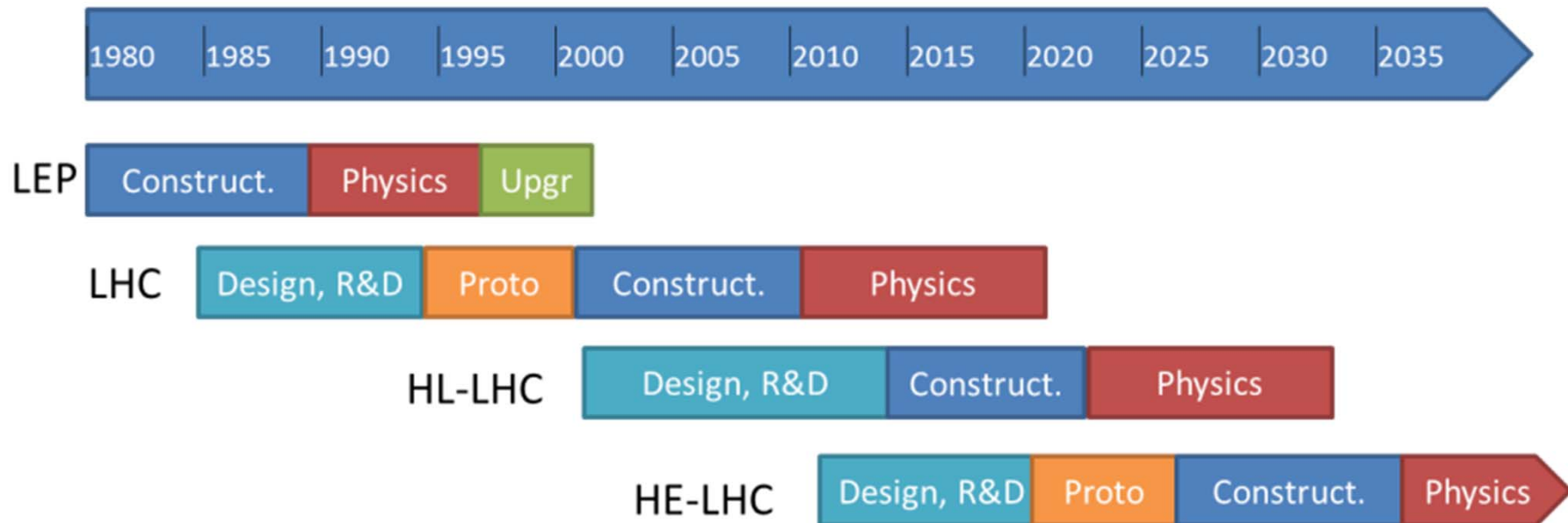

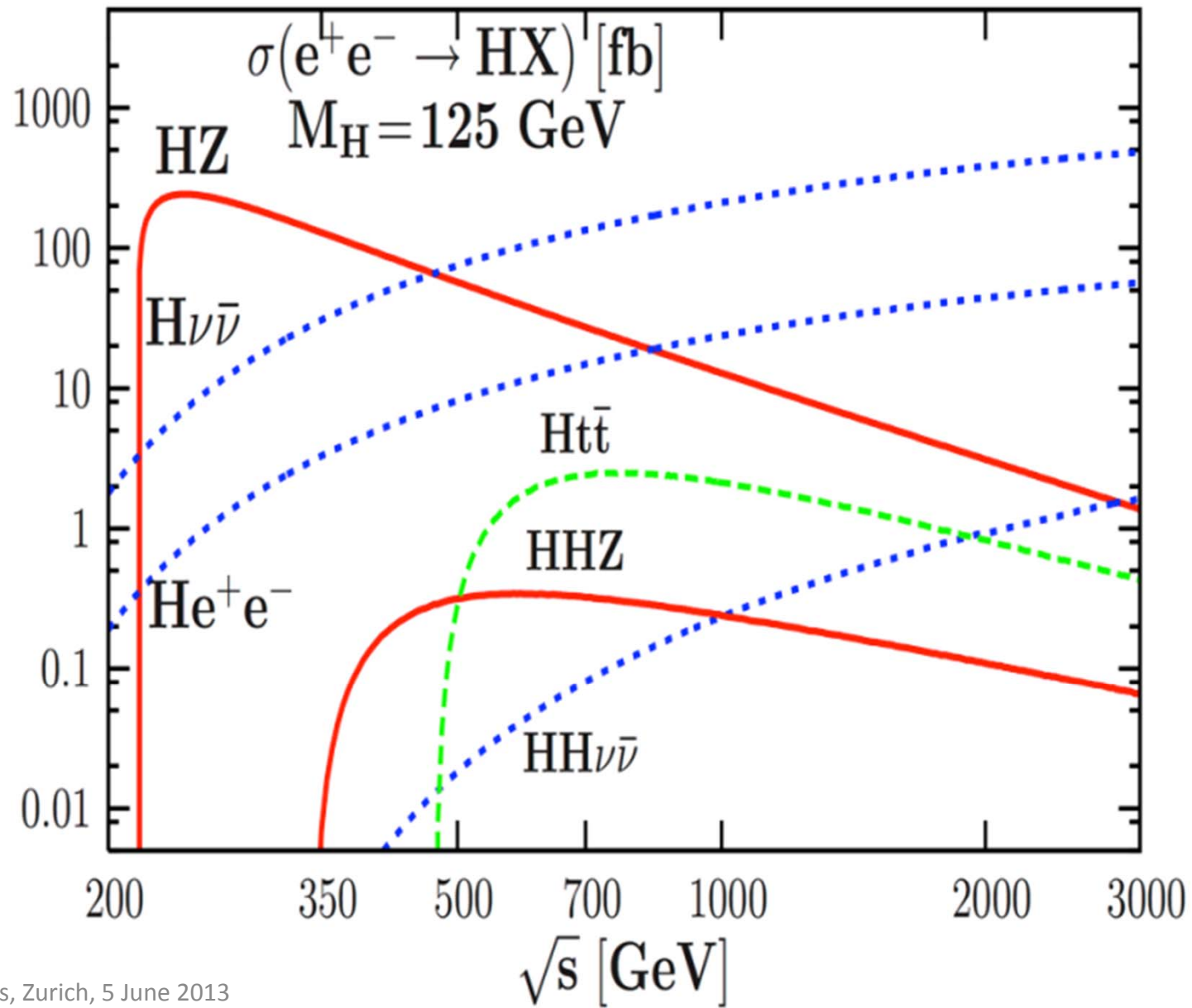

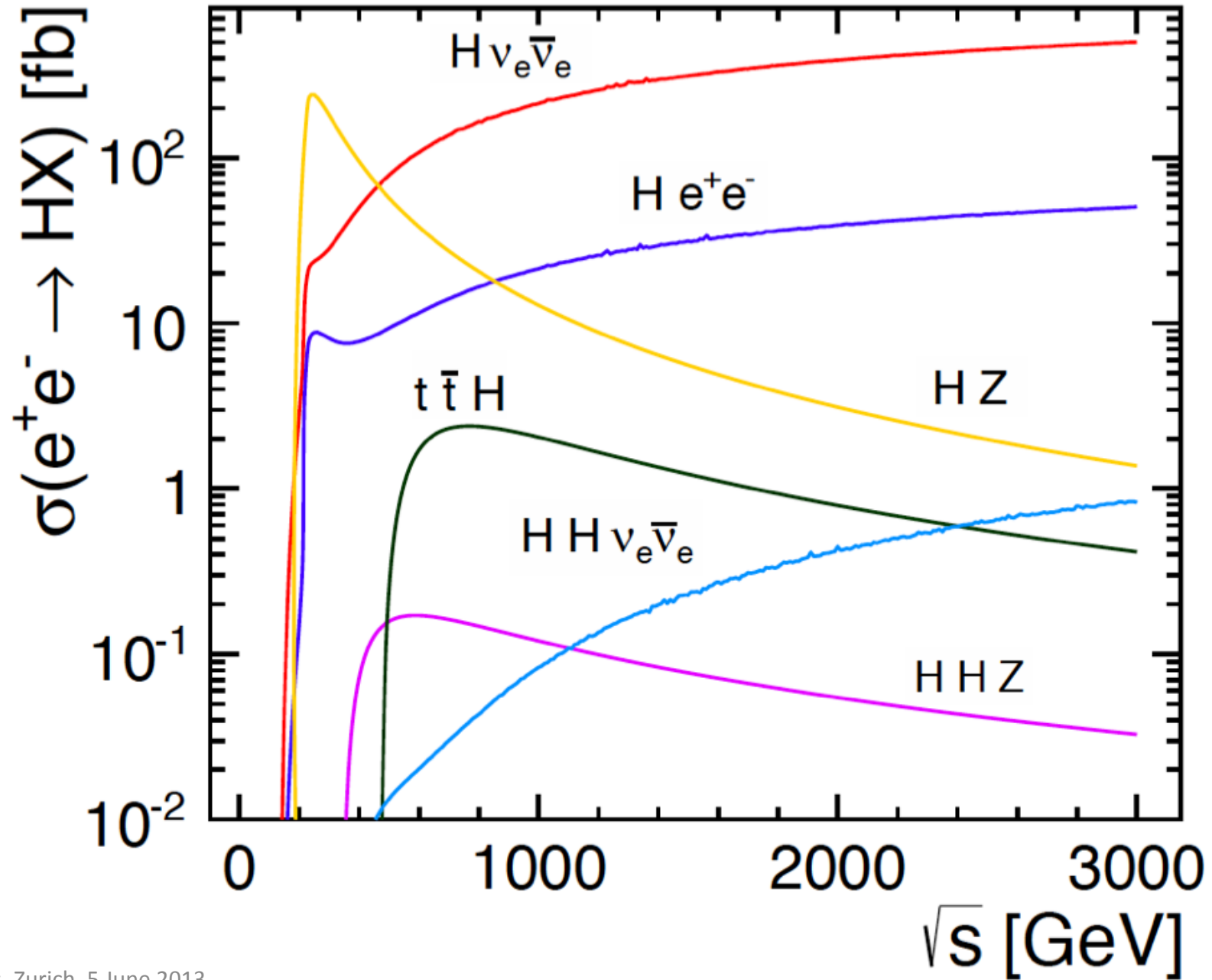

Table 1: Parameters for LEP3 and TLEP compared with LEP2.

Parameter	LEP2	LEP3	TLEP-Z	TLEP-H	TLEP-t
beam energy E_b [GeV]	104.5	120	45.5	120	175
circumference [km]	26.7	26.7	80	80	80
beam current [mA]	4	7.2	1180	24.3	5.4
# bunches/beam	4	4	2625	80	12
# e^- /beam [10^{12}]	2.3	4.0	2000	40.5	9.0
horizontal emittance [nm]	48	25	30.8	9.4	20
vertical emittance [nm]	0.25	0.10	0.15	0.05	0.1
bending radius [km]	3.1	2.6	9.0	9.0	9.0
partition number J	1.1	1.5	1.0	1.0	1.0
momentum compaction α , [10^{-3}]	18.5	8.1	9.0	1.0	1.0
SR power/beam [MW]	11	50	50	50	50
β_x^* [m]	1.5	0.2	0.2	0.2	0.2
β_y^* [cm]	5	0.1	0.1	0.1	0.1
σ_x^* [μm]	270	71	78	43	63
σ_y^* [μm]	3.5	0.32	0.39	0.22	0.32
hourglass F_{hg}	0.98	0.67	0.71	0.75	0.65
$E_{loss}^{SR}/\text{turn}$ [GeV]	3.41	6.99	0.04	2.1	9.3
$V_{RF,tot}$ [GV]	3.64	12.0	2.0	6.0	12.0
$\delta_{max,RF}$ [%]	0.77	4.2	4.0	9.4	4.9
ξ_x/IP	0.025	0.09	0.12	0.10	0.05
ξ_y/IP	0.065	0.08	0.12	0.10	0.05
f_s [kHz]	1.6	3.91	1.29	0.44	0.43
E_{acc} [MV/m]	7.5	20	20	20	20
eff. RF length [m]	485	600	100	300	600
f_{RF} [MHz]	352	1300	700	700	700
δ_{rms}^{SR} [%]	0.22	0.23	0.06	0.15	0.22
$\sigma_{z,rms}^{SR}$ [cm]	1.61	0.23	0.19	0.17	0.25
L/IP [$10^{32}\text{cm}^{-2}\text{s}^{-1}$]	1.25	107	10335	490	65
number of IPs	4	2	2	2	2
beam lifetime [min]	360	16	74	32	54
Υ_{BS} [10^{-4}]	0.2	10	4	15	15
$n_c/\text{collision}$	0.08	0.60	0.41	0.50	0.51
$\Delta E^{BS}/\text{col.}$ [MeV]	0.1	33	3.6	42	61
$\Delta E_{rms}^{BS}/\text{col.}$ [MeV]	0.3	48	6.2	65	95

ES Open Symp. Contr. ID=173

High Lumi: precision

ATLAS Preliminary (Simulation)

$\sqrt{s} = 14 \text{ TeV}$: $\int L dt = 300 \text{ fb}^{-1}$; $\int L dt = 3000 \text{ fb}^{-1}$
 $\int L dt = 300 \text{ fb}^{-1}$ extrapolated from 7+8 TeV

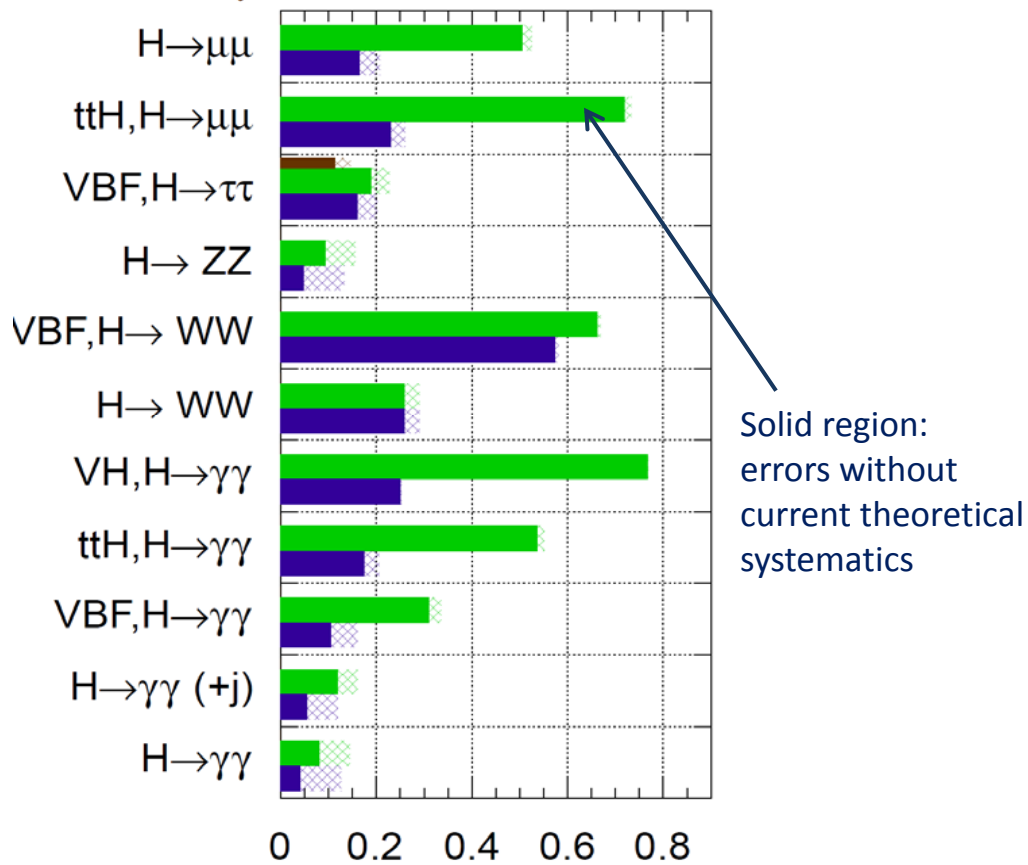

ATLAS Preliminary (Simulation)

$\sqrt{s} = 14 \text{ TeV}$: $\int L dt = 300 \text{ fb}^{-1}$; $\int L dt = 3000 \text{ fb}^{-1}$
 $\int L dt = 300 \text{ fb}^{-1}$ extrapolated from 7+8 TeV

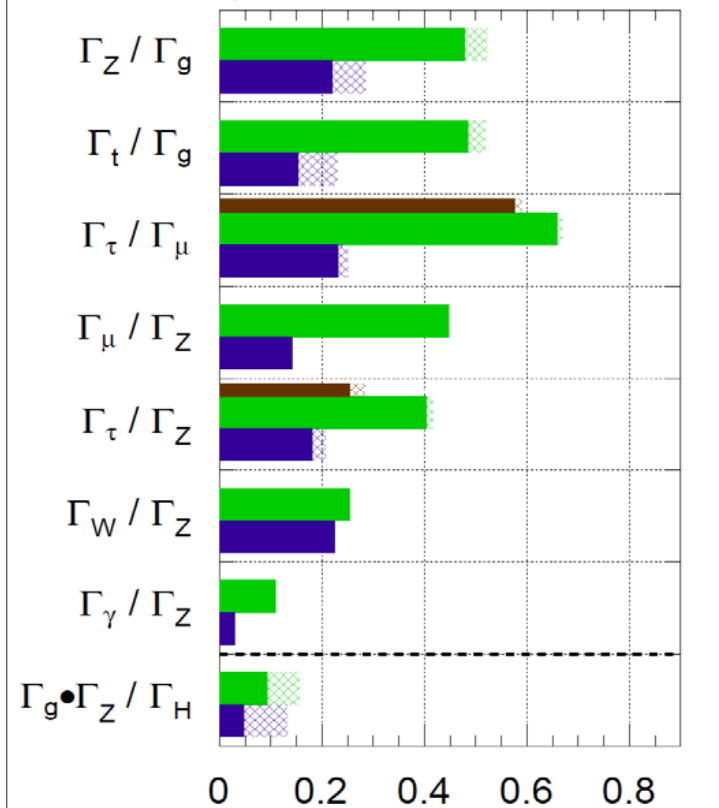

Solid region:
errors without
current theoretical
systematics

Latsis, Zurich, 5 June 2013
P Jenni, Freiburg and CERN

$\frac{\Delta\mu}{\mu}$

From 'High Energy Frontier'
presented by Marcella Diemoz

$$\frac{\Delta(\Gamma_X/\Gamma_Y)}{\Gamma_X/\Gamma_Y} \sim 2 \frac{\Delta(\kappa_X/\kappa_Y)}{\kappa_X/\kappa_Y}$$

Sensitivity to Vector Boson Scattering at HL-LHC

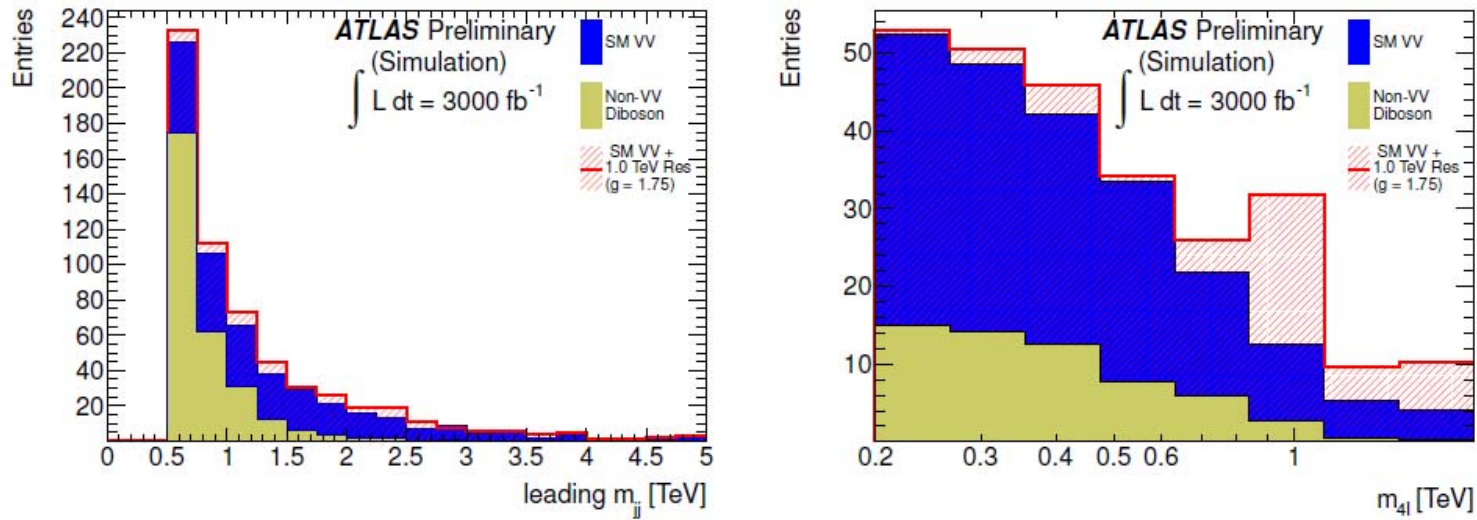
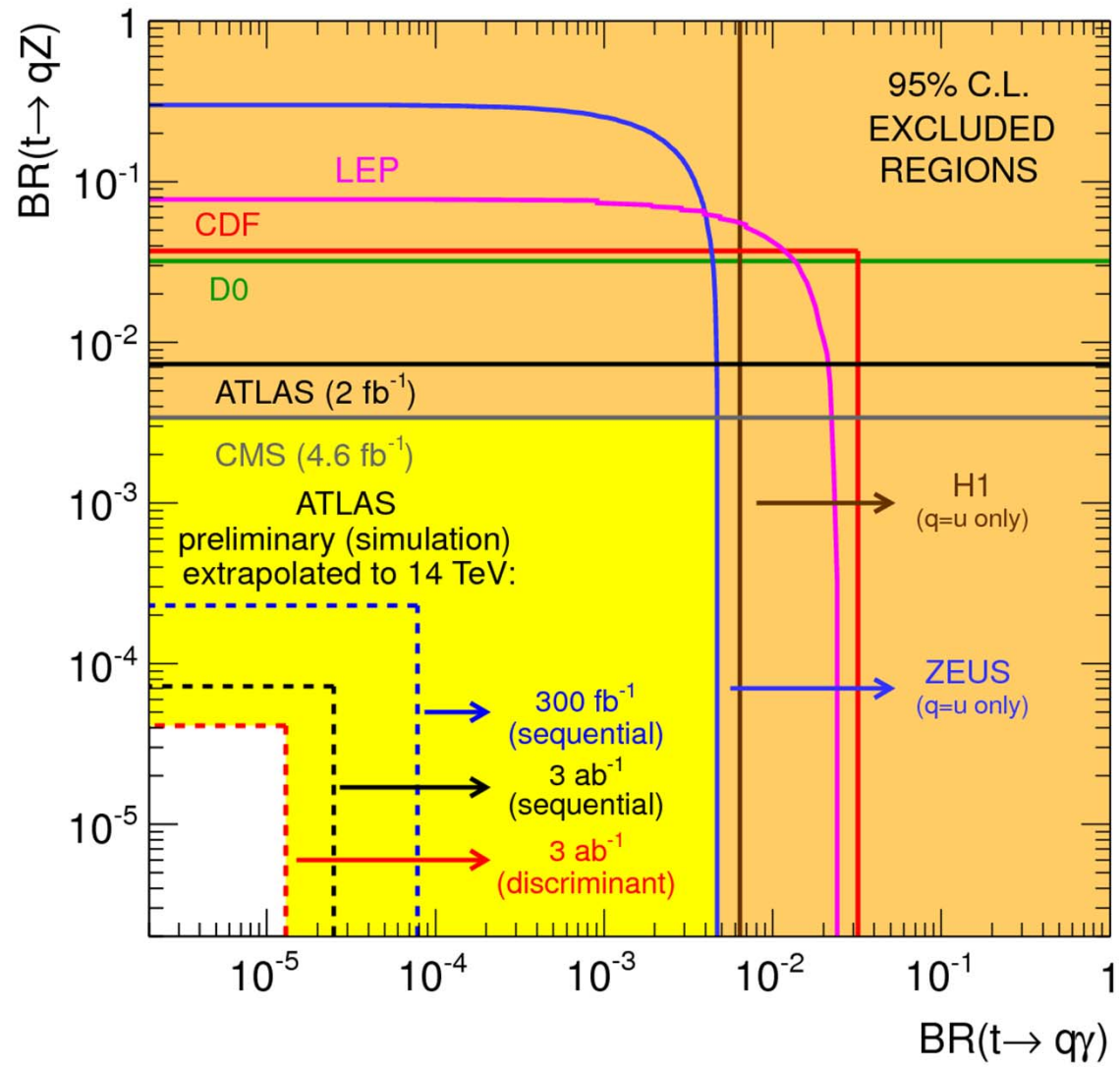

Figure 2: The leading jet-jet invariant mass (m_{jj}) distribution for simulated events in the $pp \rightarrow ZZ + 2j \rightarrow \ell\ell\ell\ell + 2j$ channel (left), and the reconstructed 4-lepton mass ($m_{4\ell}$) spectrum for this channel after requiring $m_{jj} > 1$ TeV (right). The spectra are normalized to 3000 fb^{-1} .

model	300 fb^{-1}	3000 fb^{-1}
$m_{\text{resonance}} = 500 \text{ GeV}, g = 1.0$	2.4σ	7.5σ
$m_{\text{resonance}} = 1 \text{ TeV}, g = 1.75$	1.7σ	5.5σ
$m_{\text{resonance}} = 1 \text{ TeV}, g = 2.5$	3.0σ	9.4σ

Table 5: Summary of expected sensitivity to anomalous VBS ZZ signal at $\sqrt{s} = 14$ TeV, quoted in the terms of the expected number of Gaussian σ in significance.

ATLAS-PHYS-PUB-2012-005



In principle a plan for all (?) is possible (for LHC exploitation): **2018-2020 is critical time**

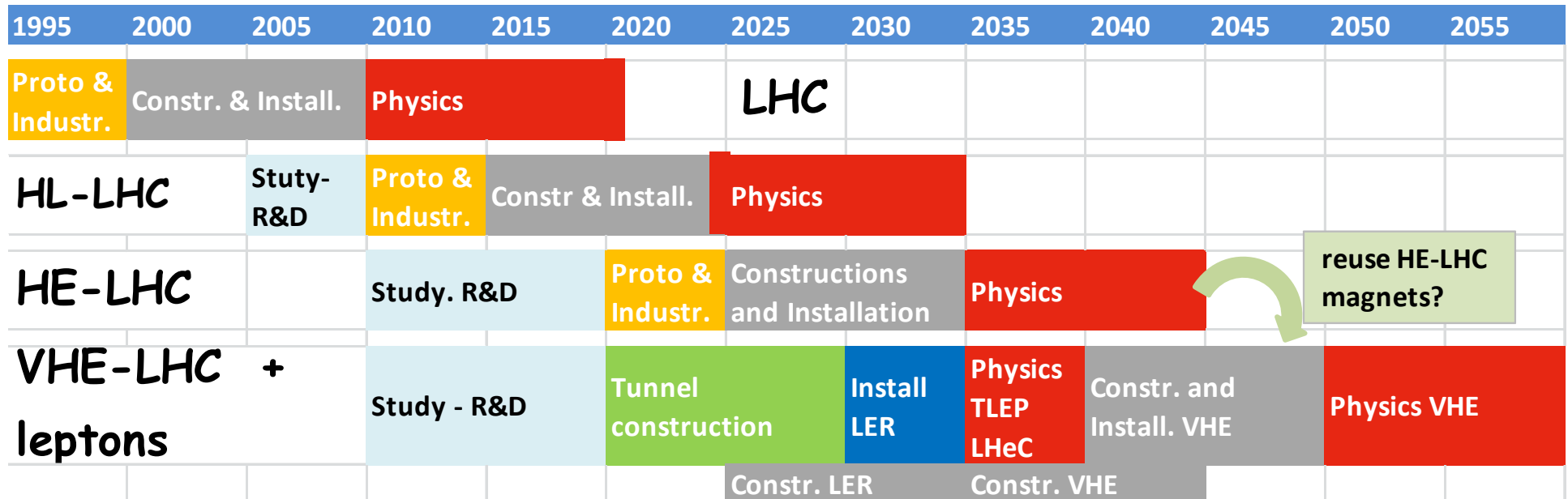

- According to Physics needs, the 80 km tunnel can:
 - Be alternative to HE-LHC
 - Or complementary to HE-LHC
 - Accomodating at negligible extra-cost TLEP and VLHeC (this last at 50GeV/5TeV and 350 GeV/50-100 TeV)
 - Skipping TLEP/VLHeC may shorten 5-10 years VHE-LHC